

Don't forget to apply the brake when you take a break.

THE POWER OF
REDARC[®]

Every year the number of runaway vehicles increases... simply because the operator has forgotten to apply the hand brake when leaving the vehicle.

There are reports where incidents have caused significant damage and personal injury... soon it may even cause a fatality.

Apart from the obvious risk of damage to the runaway vehicle, it can cause damage to other vehicles, the workplace environment and - worst of all - to people.

There is also the concern that some vehicle operators try to chase their runaway vehicles and enter the cab to try and stop them - a practice that can result in serious injury or death.

These situations can all be easily prevented by installing a REDARC HBA1224 Hand Brake Alarm.

Benefits

- Cost effective protection against damage caused by runaway vehicles
- Many mine sites have adopted the HBA1224 as a mandatory Health and Safety installation
- Warns you when you forget to apply the hand brake
- Horn output ensures others will be warned
- Designed to fit any vehicle



MADE IN AUSTRALIA



The increasing concern with runaway vehicles on mine sites saw the State Mining Engineer in WA, Mr. Martin Knee, release a Mines Safety Bulletin on January 4th 2008 regarding "unattended vehicles rolling away".

The bulletin highlights a number of recent incidents that have caused significant damage and personal injury. One such incident describes an operator loading the trailers of a road train parked on a "very slight" slope.

The truck and trailer began rolling downhill and eventually came to rest 120 metres from the loading area in a creek. After the incident the vehicle was inspected and the park brake was found to be disengaged. The bulletin also states the primary concern by some vehicle operators attempting to pursue and enter the cabs of their runaway vehicles to try and stop them - a practice that can result in serious injury or death.

One of the mines safety bulletin recommendations is to "investigate and implement systems such as warning alarms to alert the operator that the park brake has not been engaged when the vehicle door has been opened".

In response to an increasing number of customer enquiries and the above recommendation, REDARC released the HBA1224 Hand Brake Alarm which can be utilised in a wide variety of vehicles including passenger, commercial, mining and transport applications.

The HBA1224 is a compact unit measuring 50mm x 30mm x 25mm - small enough to be dash-mounted in most vehicle or machinery cabins. It has mounting tabs which may be drilled for screw mounting.

The HBA1224 features a built in LED warning light and piezzo buzzer, but can also be used to trigger an external LED, lamp or alarm (for example, a horn relay).



Actual instances of runaway vehicles causing damage to the vehicles and their environments

HBA1224 installation

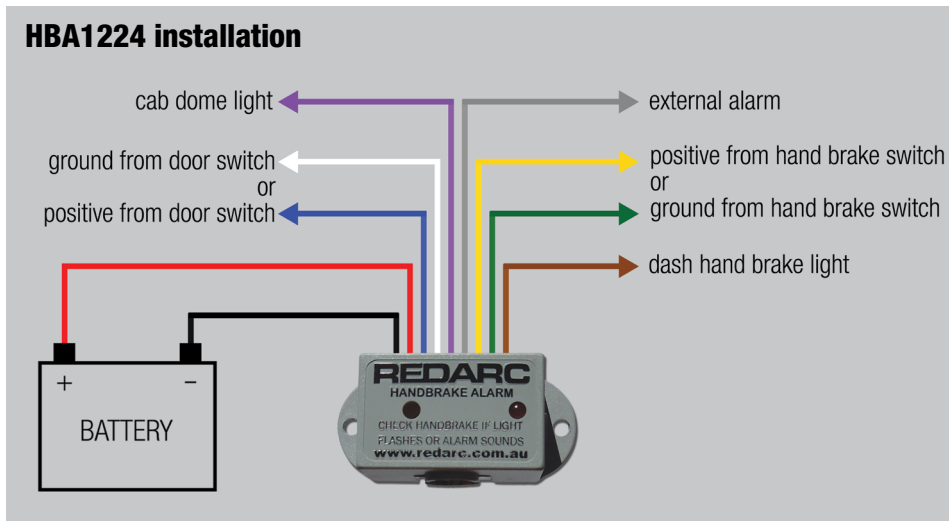

Specifications

Part number	HBA1224
DC input voltage range	9V-32V
Current draw (alarm off)	<2mA
Current draw (alarm on)	30mA
Audible warning	Piezzo buzzer
Visual warning	Red LED
External warning outputs	Ground output (0.5A max)
Weight	75g
Dimensions	50mm x 30mm x 25mm
Warranty	2 years

See the REDARC HBA1224 Hand Brake Alarm at your nearest auto-electrician or 4WD specialty store.



N3533

REDARC Electronics

ABN 77 136 785 092

power@redarc.com.au

23 Brodie Road (North)
Lonsdale, South Australia
Australia 5160

Australia

Phone (08) 8322 4848

Fax (08) 8387 2889

International

Phone +61 8 8322 4848

Fax +61 8 8387 2889

Copyright © 2012 REDARC Electronics Pty Ltd. All rights reserved.
3975-HBA-121219

THE POWER OF

REDARC®