



FITTING INSTRUCTIONS



PRODUCT :

PIAK GENESIS LOOP WINCH BAR

VEHICLE MODEL :

TOYOTA LANDCRUISER 300 SERIES

PRODUCT PART NUMBER :

PK105LC300G_RBO_URPMB

PK105LC300G_RBO_URPBO

PK105LC300G_RMB_URPMB

PK105LC300G_RMB_URPBO

FITTING TIME :

Approx. 3 hours

TABLE OF CONTENTS	Page
Tools Required	5
Part List	5
Component Overview	9
Toque Setting of Fastener	9
Fitting Procedure	10

BULL BAR SAFETY NOTICE :

INSTALLATION SHOULD ONLY BE DONE BY APPROPRIATELY QUALIFIED OR EXPERIENCED PERSONS IN ACCORDANCE WITH THESE INSTRUCTIONS.

IT IS THE RESPONSIBILITY OF THE INSTALLER TO ENSURE THAT THE PRODUCT IS CORRECTLY FITTED.

WARNING :

Do not attach Vehicle Frontal Protection System (VFPS) to the vehicle using anchorages not intended for this purpose. (e.g. engine mounting bolts)

Do not use this product for any vehicle make or model, other than those specified by the VFPS manufacturer.

Do not remove the plaque or label from the VFPS.

Do not modify the structure of the VFPS in any way.

The VFPS has been produced to provide continued functionality of parking sensors and other "driver assist" features as closely as possible to Original Equipment. However, as all possible road conditions and combination of other accessories fitted to the vehicle which may affect functionality characteristics cannot be anticipated, **the driver remains responsible at all times for properly controlling the vehicle, monitoring all "driver assist" features and intervening where required to ensure the vehicle is safely operated.**

IMPORTANT INFORMATION :

Before installing the VFPS :

Check that all components, as listed in the assembly table, are available.

Thoroughly read all instructions.

This product or its fasteners must not be modified in any way.

These instructions are accurate as at the revision date and do not take into account any changes made by the vehicle manufacturer to vehicle design after the revision date or other accessories that are or have been fitted to the vehicle. Piak cannot be held responsible for such changes and appropriate enquiries should be made before installation.

Before installing, inspecting and/or maintaining the VFPS, the work space should be safe and clear of fuel, debris, electrical or other components.

During installation :

It is the responsibility of the installer to confirm correct operation/clearance of all components. All holes drilled shall have all burrs and swarf removed then coated with a suitable rust preventative paint.

Ensure that all hardware is fastened to torque list as detailed in these instructions.

MAINTENANCE AND CARE :

To ensure continued safety and correct operation of the product, the VFPS must be routinely inspected and regularly serviced (including bolt torque checked for correct tension) by an appropriately qualified or experienced person.

The high tensile fasteners supplied with this product were used to achieve the specified rating. If replacement of the fasteners is required, fasteners of the same rating and quality must be used.

If this VFPS is fitted with a hinged number plate bracket, extra care must be taken when returning back to public roads following the use of the winch or conducting a deep water crossing.

The driver must ensure that the number plate bracket is returned back to the down position allowing full visibility of the number plate when returning to public roads.

EQUIPMENT :

These safety products should, at a minimum, be used when fitting or working on the product.



Protective Glasses



Hearing Protection

Installation in accordance with these instructions and adherence to warnings will ensure compliance with relevant regulatory and safety standards as at the revision date.

Failure to adhere to these instructions may affect the roadworthiness of the vehicle or cause personal injury, death or damage to property.

BY USING THIS PRODUCT YOU ACKNOWLEDGE AND AGREE THAT TO THE EXTENT PERMITTED BY LAW PIAK WILL NOT ACCEPT LEGAL OR OTHER LIABILITY FOR ANY LOSS, INJURY OR DAMAGE CAUSED BY INCORRECT OR INAPPROPRIATE INSTALLATION OR USE OF THE PRODUCT.

TOOLS REQUIRED

- | | | |
|--------------------------------|-----------------------------|---------------------------------------|
| 1. Metric Socket and Spanners | 2. 2" Masking tape | 3. Marking pen |
| 4. Drill and metric drill bits | 5. Test lamp or multi-meter | 6. Phillip and flat head screw driver |
| 7. Torque wrench | 8. Air saw | |

PART LIST

Important : Check contents of fitting kit before commencing fitment and report any discrepancies.

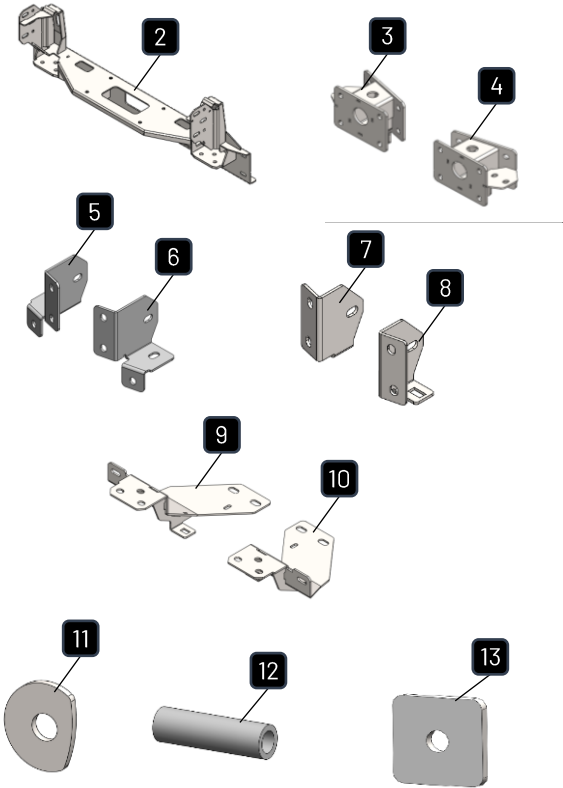
STEEL BULL BAR			
ITEM	COMPONENT NAME	Q'ty	REMARKS
1	PIAK Genesis Loop Bar	1	
MOUNTING BRACKET			
ITEM	COMPONENT NAME	Q'ty	REMARKS
2	Mounting Bracket	1	
3	Chassis Support RH	1	
4	Chassis Support LH	1	
5	Chassis Support Inside RH	1	
6	Chassis Support Inside LH	1	
7	Chassis Support Outside RH	1	
8	Chassis Support Outside LH	1	
9	Chassis Support Bottom RH	1	
10	Chassis Support Bottom LH	1	
11	Spacer 3 mm	2	
12	Tube OD19x68 mm.	2	
13	Square Washer 5 mm.	4	
14	Hex Bolt M12x100x1.25	2	
15	Spring Washer M12	2	
16	Flat Washer M12	4	
17	Hex Nut M12x1.25	2	
18	Hex Bolt M10x35x1.5 EDP	14	
19	Hex Bolt M10x40x1.5 EDP	4	
20	Spring Washer M10 EDP	18	
21	Flat Washer M10 EDP	36	
22	Hex Nut M10x1.5 EDP	18	
23	Hex Bolt M12x30x1.25 EDP	2	
24	Spring Washer M12 EDP	2	
25	Flat Washer M12 EDP	2	

PART LIST

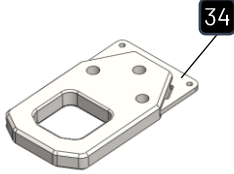
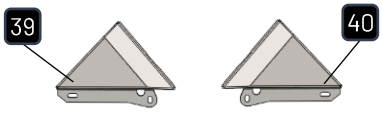
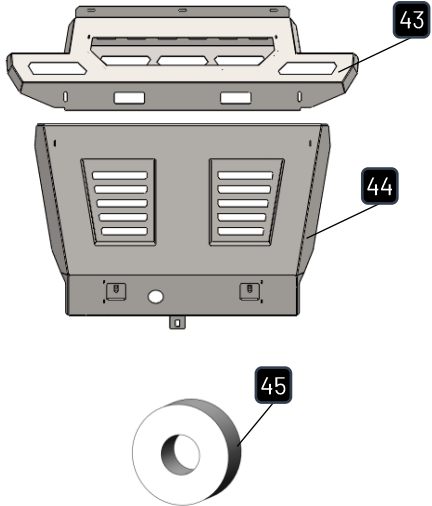
BAR TO MOUNTING BRACKET			
ITEM	COMPONENT NAME	Q'ty	REMARKS
26	Hex Bolt M12x1.5x35	6	
27	Spring Washer M12	6	
28	Flat Washer M12	12	
29	Hex Nut M12x1.5	6	
30	Hex Bolt M10x1.25x35	4	
31	Spring Washer M10	4	
32	Flat Washer M10 OD20	8	
33	Flange Nut M10x1.25	4	
RECOVERY POINT			
ITEM	COMPONENT NAME	Q'ty	REMARKS
34	Recovery Point	2	
35	Hex Bolt M12x1.5x55 Gr10.9 EDP	6	
36	Spring Washer M12 EDP	6	
37	Flat Washer M12 EDP	12	
38	Hex Nut M12x1.5 Gr10.9 EDP	6	
INFILL			
ITEM	COMPONENT NAME	Q'ty	REMARKS
39	Infill RH	1	
40	Infill LH	1	
41	Stainless screw Thin-Phillips Head Screw M6x16x1.0	4	
42	Cage Nut M6x1.0x2T	2	
RADIATOR PLATE			
ITEM	COMPONENT NAME	Q'ty	REMARKS
43	Radiator Plate Top	1	
44	Radiator Plate Bottom	1	
45	Spacer 10 mm.	2	
46	Hex Bolt M6x20x1.0 EDP	3	
47	Spring Washer M6 EDP	3	
48	Flat Washer M6 EDP	3	
49	Cage Nut M6x1.0x3T	3	
50	Hex Bolt M8x25x1.25 EDP	1	
51	Hex Bolt M8x30x1.25EDP	6	
52	Spring Washer M8 EDP	7	
53	Flat Washer M8 EDP	7	
54	Cage Nut M8x1.25x3.2T	3	
55	Cage Nut M8x1.25x4T	2	

PART LIST

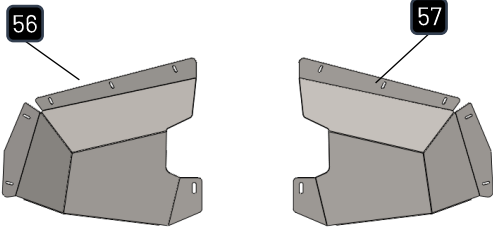
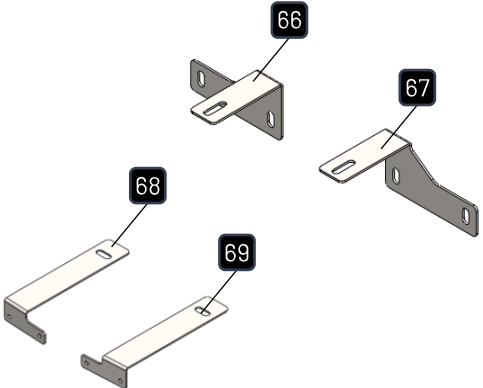
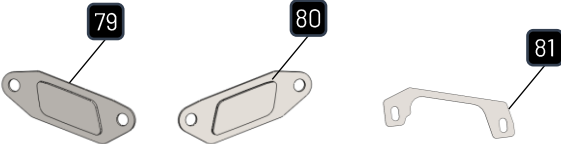
SIDE PLATE			
ITEM	COMPONENT NAME	Q'ty	REMARKS
56	Side plate RH	1	
57	Side plate LH	1	
58	Hex Bolt M6x20x1.0 EDP	10	
59	Spring Washer M6 EDP	10	
60	Flat Washer M6 EDP	10	
61	Cage Nut M6x1.0x3T	10	
62	Hex Bolt M8x30x1.25EDP	2	
63	Spring Washer M8 EDP	2	
64	Flat Washer M8 EDP	2	
65	Cage Nut M8x1.25x4T	2	
FRONT GRILL BRACKET			
ITEM	COMPONENT NAME	Q'ty	REMARKS
66	Front Grill Bracket Inside RH	1	
67	Front Grill Bracket Inside LH	1	
68	Front Grill Bracket Outside RH	1	
69	Front Grill Bracket Outside LH	1	
70	Hex Bolt M6x20x1.0 EDP	4	
71	Spring Washer M6 EDP	4	
72	Flat Washer M6 EDP	4	
73	Thread Cutting Screws (M5x15) EDP	4	
74	Flat Washer M5 EDP	4	
75	Hex Bolt M8x20x1.25EDP	2	
76	Spring Washer M8 EDP	2	
77	Flat Washer M8 EDP	4	
78	Flange Nut M8x1.25	2	
HEAD LAMP WASHER			
ITEM	COMPONENT NAME	Q'ty	REMARKS
79	head lamp washer cover RH	1	
80	head lamp washer cover LH	1	
81	head lamp washer Bracket	2	
82	Flat Washer M6 EDP	4	
83	Flange Nut M6x1.0 EDP	4	

PART LIST

LICENSE PLATE BRACKET

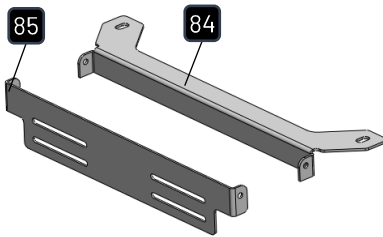
ITEM	COMPONENT NAME	Q'ty	REMARKS
84	License Plate Bracket _Inner	1	
85	License Plate Bracket _Outer	1	
86	Hex Bolt M6x20x1.0 EDP	2	
87	Spring Washer M6 EDP	2	
88	Flat Washer M6 EDP	4	
89	Flange Nut M6x1.0 EDP	2	
90	Button Head Bolt M6x20x1.0 SUS	2	
91	Flat Washer M6 OD14 SUS	4	
92	Nylon Washer M6	4	
93	Nyloc Nut M6x1.0 SUS	2	
94	Hex Bolt M8x20x1.25	2	
95	Spring Washer M8	2	
96	Flat Washer M8	4	
97	Flange Nut M8x1.25	2	

CAMERA BRACKET

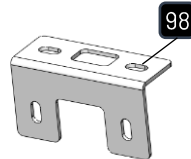
ITEM	COMPONENT NAME	Q'ty	REMARKS
98	Camera Bracket	1	
99	Button Head Bolt M5x15x0.8	2	
100	Spring Washer M5	2	
101	Flat Washer M5	4	
102	Hex Nut M5x0.8	2	
103	Hex Bolt M6x20x1.0	2	
104	Spring Washer M6	2	
105	Flat Washer M6	4	
106	Flange Nut M6x1.0	2	

ACCESSORIES

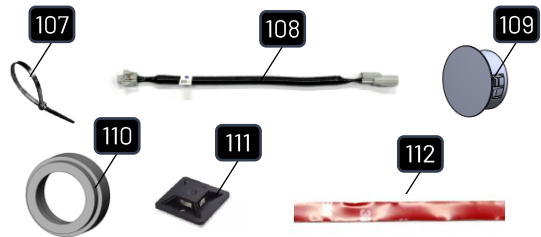
ITEM	COMPONENT NAME	Q'ty	REMARKS
107	Cable Tie (L=150 mm)	10	
108	Sensor Loom Extension	2	
109	Sensor blanking plugs	4	
110	Sensor Housing	4	
111	Cable Tie Mount	8	
112	Double sided adhesive 3M (10x150mm.)	3	

** Refer to the Wiring Harness (PK105LC300G-WL) installation manual for wiring harness installation instructions.

COMPONENTS OVERVIEW

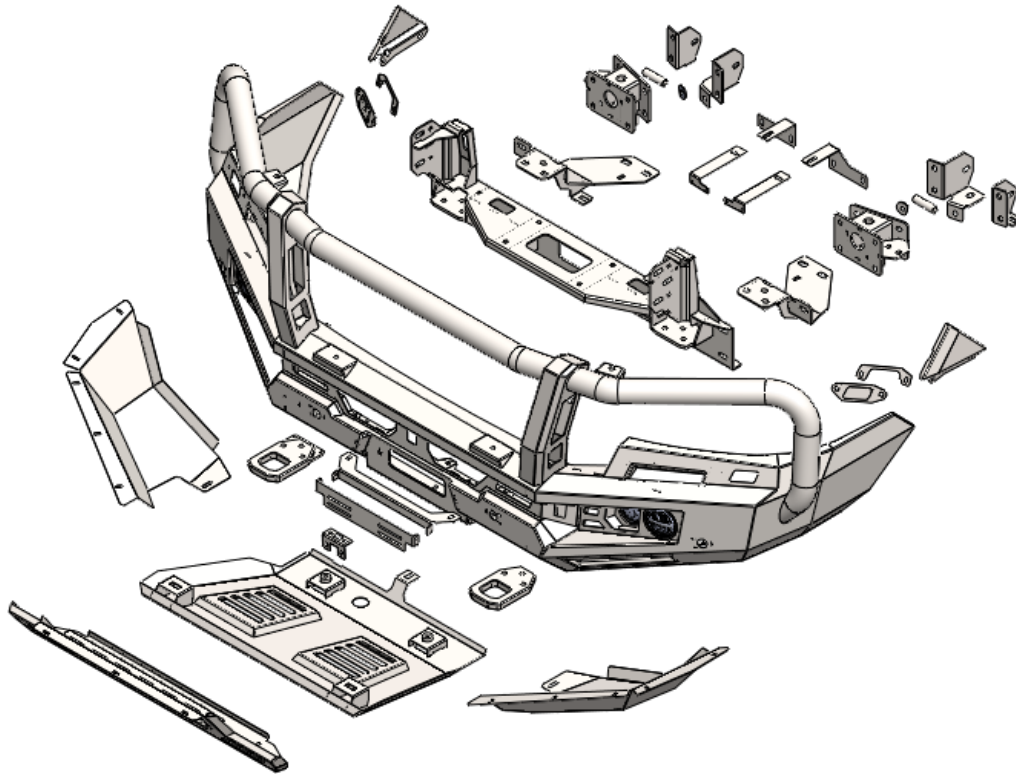

TORQUE SETTING OF FASTENER

Mounting bolts must be tightened to torque's specified following ;

Bolt Diameter (mm.)	Class 8.8		Class 10.9	
	Torque (Nm.)	Torque (ft-lb.)	Torque (Nm.)	Torque (ft-lb.)
M6	10.5	7.7	15	11.1
M8	25.5	18.8	36.5	26.9
M10	50.5	37.2	72.2	53.3
M12	88	64.9	126	92.9
M14	140	103	200	148

FITTING PROCEDURE



- 01** Locate the vehicle in a suitable position.
Disconnect the battery.



- 02** Mask both sides with tape as shown in the picture aligning it with the factory flare. Make sure to follow the alignment directions and refer to the lines on the side of the car to ensure accurate positioning.

Carefully remove the flares and trim along the masked line using an air-hacksaw or another appropriate tool. Once trimmed, reinstall back onto vehicle body



- 03** Carefully remove all clips retaining the front under-bonnet cover and set the cover and clips aside.



- 04** Disconnect the factory bumper harness via these 3 plugs at the front drivers side.

FITTING PROCEDURE

- 05** Disconnect the hose for the headlamp washers at the front passenger side.



- 06** From under front of vehicle, remove outer plastic covers, five 10mm head bolts and one 12mm nylon nut.



- 07** From lower edge of bumper, remove four 10mm head bolts.



- 08** Under front wheel arch remove two push pull clips and one T25 Torx screw (per side) from inner guards.

FITTING PROCEDURE

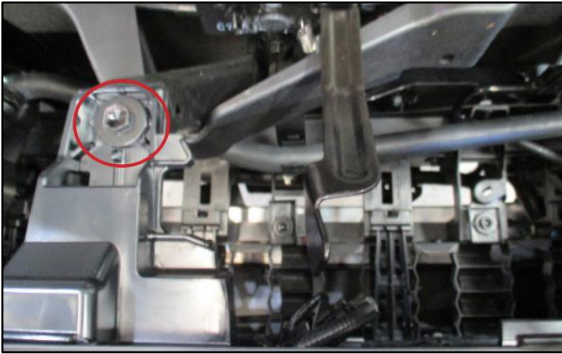

- 09** Between headlights, remove three 10mm head bolts from rear of grill



- 10** Remove one push pull clip per side from guard/bumper join.



- 11** Gently pull outer wing away from guard and under headlights to release from attachment clips.
Pull centre of grille to release from attachment clips.
Remove bumper.

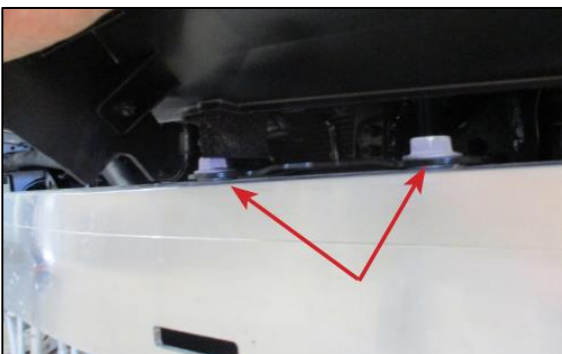

- 12** Bumper support remove four 17mm bolts top and bottom of alloy bumper support. Remove alloy bumper support.



FITTING PROCEDURE



- 13 Remove original tie down hooks from underside of cross member, two 17mm head bolts.

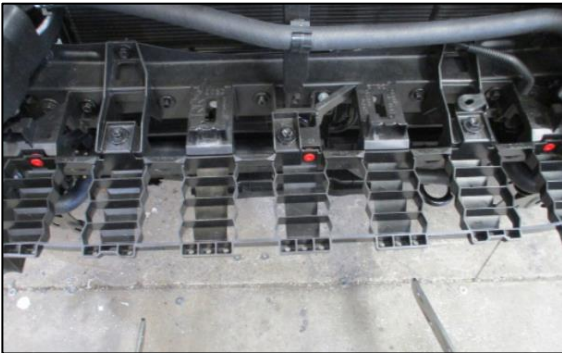

- 14 Remove grille support, six 10mm head bolts. Pull up and forward to release

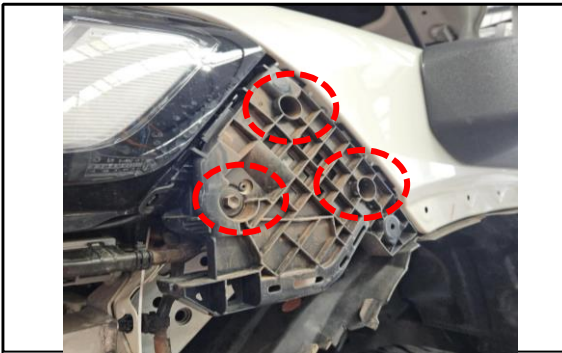

- 15 Remove bolts retaining factory bumper retention panel and remove the panel

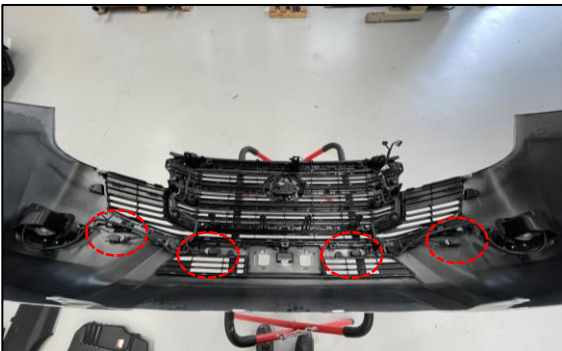

- 16 Carefully disconnect the wiring loom from the parking sensors and remove from the factory bumper, making sure to note the position and orientation of each sensor for accurate reinstallation.



x4

FITTING PROCEDURE

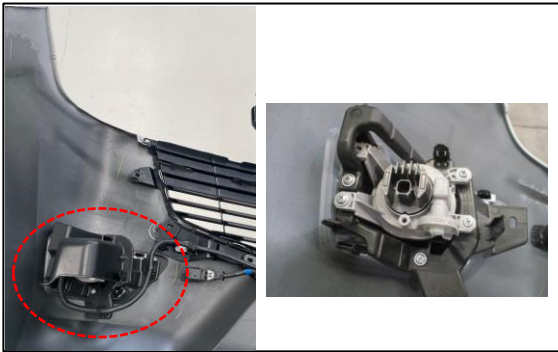

- 17 unclip outer housing from behind fog lights. Remove fog light from bumper.

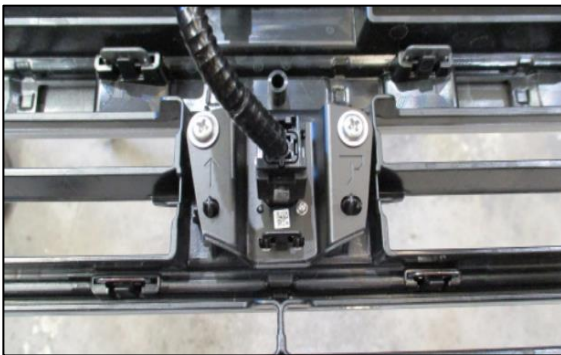

- 18 Disconnect camera and remove two Phillips head screws. Unclip outer plastic camera housing.

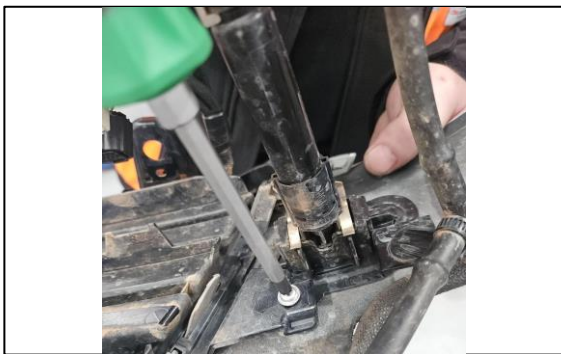

- 19 Carefully remove the headlamp washer from the original equipment (OE) bumper. Carefully disconnect hoses from the headlamp washers and set aside.

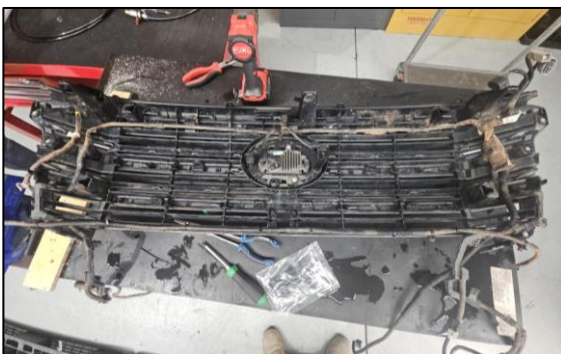

- 20 Remove clips retaining harness from outer bumper section. Carefully separate the centre grill section from the outer bumper. Install sensor extension looms onto each parking sensor connector.

FITTING PROCEDURE

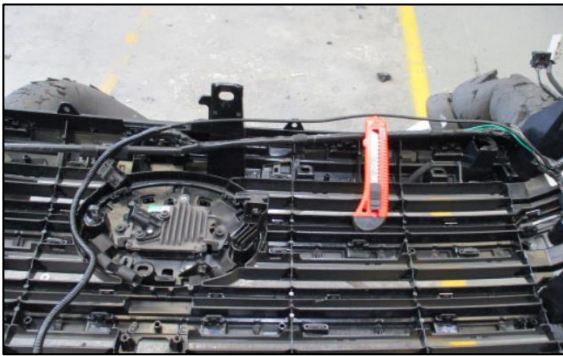

- 21 Remove wiring from clips across top rear of grille. Using a sharp knife or similar, carefully slit covering tape ensuring wiring inside is not damaged. Remove camera wiring back to join where loom separates from top to bottom. Cover wiring with Convoluted tubing. Retape top loom and run wiring down to bottom of grille with other loom.



- 22 Lower front to back cut (70mm) needs to go all the way to the back face of the shroud to allow the mount to fit. Suggest doing the same with top cut.



- 23 Also suggest trimming along the red line to make bullbar fitment easier



- 24 Now prepared for mounting bracket installation.
Fit Chassis Support Inside (Item 6) using M12 x 30 mm bolt, M12 Spring Washer and M12 flat washer

Repeat on opposite side.

FITTING PROCEDURE



25 Fit Chasis Support Outside (Item 6) using M12 x 100 mm bolts, M12 Spring Washers, 19mm OD Tubes and M12 flat washers through the outside of the chasis rail. Secure to chasis rail using Chasis Support Inside (Item 8) and M12 flat washers and M12 nuts.

Repeat on opposite side.

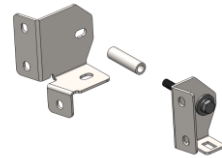

26 Place a 3 mm shim spacer (Item 11) at the chasis rail front, in the location shown. Fit Chasis Support (Item 4) using 5xM10 x 35 mm bolts, 5xM10 Spring Washers, 10xM10 flat washers and 5xM10 nuts.

Repeat on opposite side.

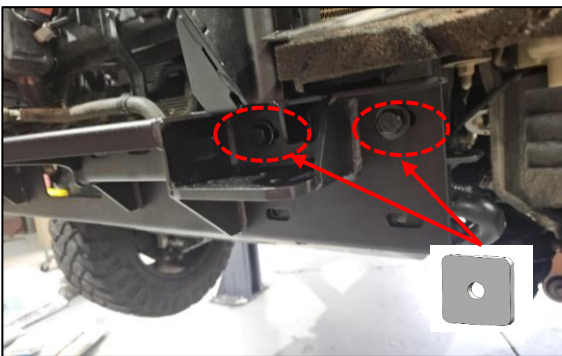

27 Secure the mounting bracket to the chasis using four M10 bolts (M10x40x1.5), along with spring washers, flat washers, Square Washer 5 mm and M10 nuts.

Ensure all bolts are tightened properly as indicated in the diagram.

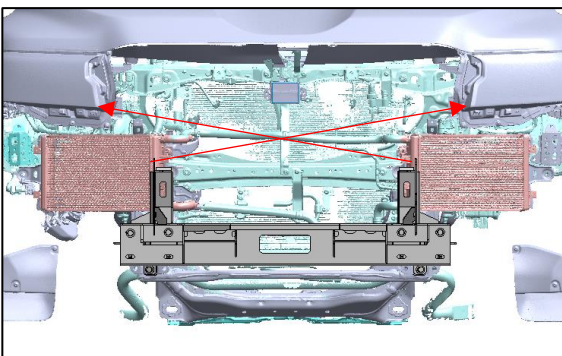

28 Adjust the mounting bracket to be centered on the vehicle by measuring from the Headlamp to the mounting bracket. As shown in the picture.

FITTING PROCEDURE

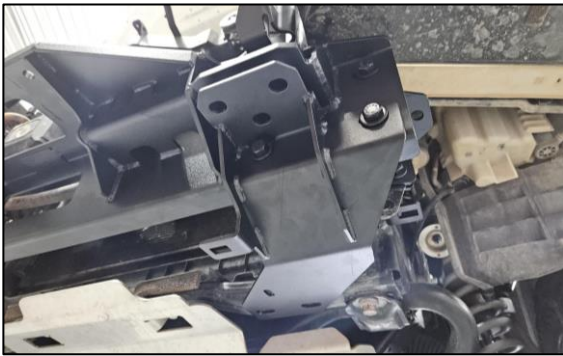

- 29** Fit Chassis Support Bottom LH (Item 10) using 2xM10 x 35 mm bolts, 2xM10 Spring Washers, 4xM10 flat washers and 2xM10 nuts.

Repeat on opposite side.



- 30** Fit the Chassis Support Bottom (Item 10) using two M12 bolts (OE).

Repeat other side



- 31** Install the recovery point (Item 34) using three M12 bolts (M12x55x1.5 Gr 10.9), along with spring washers, flat washers, and hex nuts bolts had to be installed bottom up. Ensure all components are securely tightened.

Repeat other side



- 32** Tighten all bolts as specified in the manual. Start with chassis extension to chassis bolts. Torque to spec.

If a winch needs to be installed, do so at this stage before lifting the bullbar onto the vehicle.



FITTING PROCEDURE

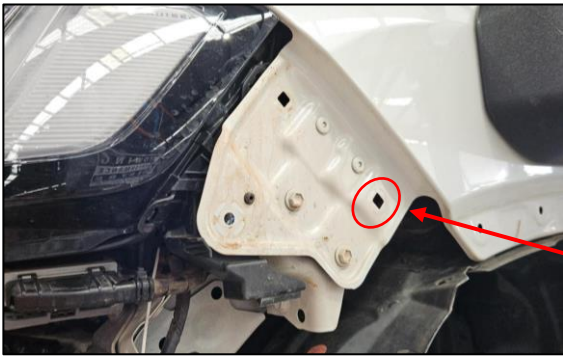

- 33** Install M6x1.0x3.T cage nuts into the lower rectangular hole.



- 34** Install the infill (Item 40) onto the vehicle. Tighten securely using two Thin-Phillips Head Screw (M6x16x1.0).

Repeat for the opposite side.



- 35** Fit the front camera to the camera bracket (Item 98) using two button head bolts (M5x15x0.8), along with spring washers, flat washers, and hex nuts, as shown., as shown in the picture.



- 36** Fit the camera bracket from step 35 to the bullbar using two hex bolts (M6x20x1.0), along with spring washers, flat washers, and hex nuts, as shown.

FITTING PROCEDURE



- 37** Clean the headlamp washer to remove dust and oil stains, then use 3M double-sided tape to attach it.



- 38** Attach the headlamp washer from step 37 to the Bullbar pressing it firmly to ensure the adhesive bonds securely with the Bullbar.



- 39** Install the headlamp washer bracket (Item 81) onto the bullbar using two M6 flange nuts and flat washers, ensuring all components are securely fastened as shown in the picture.

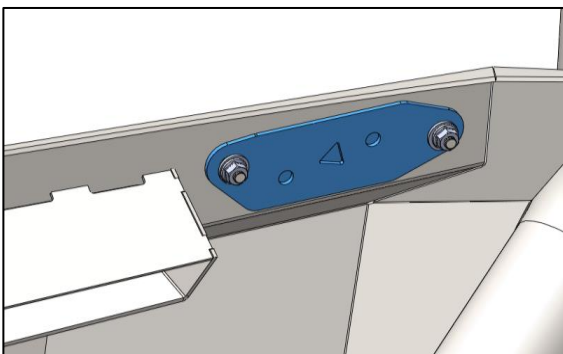

- 40** If your vehicle model does not have a headlamp washer, install the headlamp washer cover (Item 79,80) into the empty slot on the infill instead.

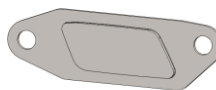

FITTING PROCEDURE



41 Insert the sensor housing onto the bull bar. Reinstall the parking sensors onto the bull bar, ensuring correct orientation and that each sensor "snaps" into place as shown.

Do this carefully.

Use pliers to widen the bracket, which will make it easier to insert the sensor.

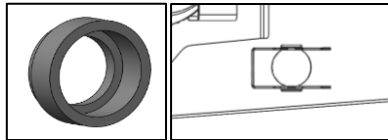

42

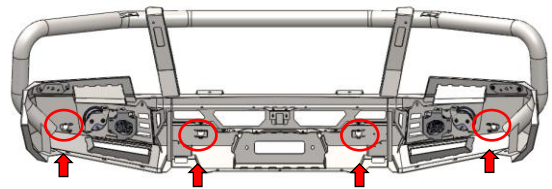

Lock the parking sensor into the sensor bracket of the bullbar using a cable tie at all points as shown in the picture.

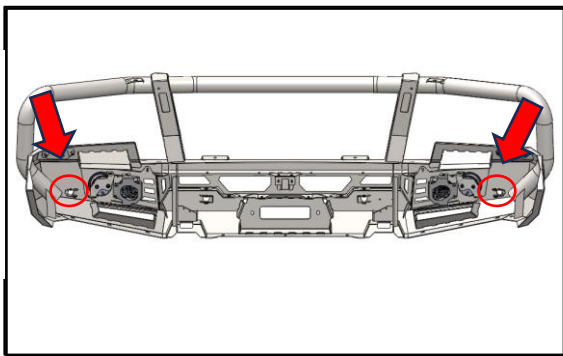

43

Connect the sensor extension looms to the parking sensor connectors on the wing side (both left and right), which have been relocated onto the bullbar.



x2



44

Assemble the license plate bracket using two M6 button head bolts, flat washers, nylon washers, and nyloc nuts as shown.

Do not fully tighten

FITTING PROCEDURE



- 45 Fit the assembled license plate bracket to the bull bar using M8 bolts (M8x20x1.25), spring washers, flat washers, and flange nuts.

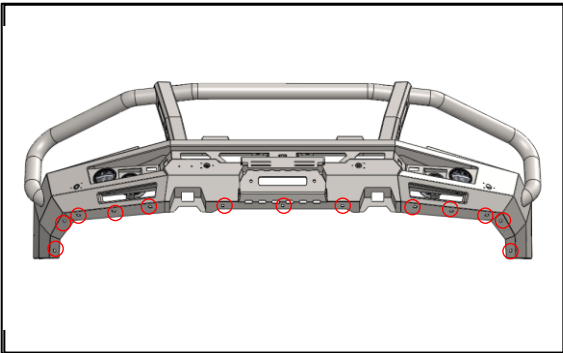

- 46 Insert thirteen M6x1.0x3T cage nuts into the designated slots on the bullbar.

if installing driving lights, do so at this stage before fitting the bullbar onto the vehicle



- 47 Before proceeding to the next step, route the Wiring Harness properly,

Referring to the **Wiring Harness (PK105LC300G-WL) installation manual**.

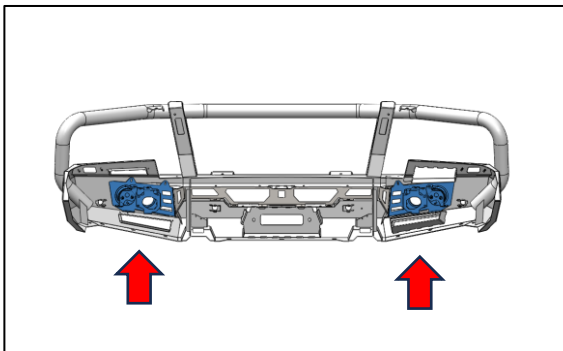

- 48 Attach the light frame to the bullbar .

Using the fitting kit and Fitting instructions .

-PKLB-LFFGOE-LC300G

-PKLB-LFN0FGOE-LC300G

FITTING PROCEDURE

**49 Caution ! : Perform Step Carefully ******Carefully reinstall the grill into position**

49.1 . Use the mounting bracket flange as a reference, then measure 35 mm to each side.

49.2 . Measure 35 mm upward from the bottom edge of the grill

49.3 . Cut the grill along the marked line using an air saw, and finish the edges neatly. **Handle this step carefully.**

Repeat for the opposite side

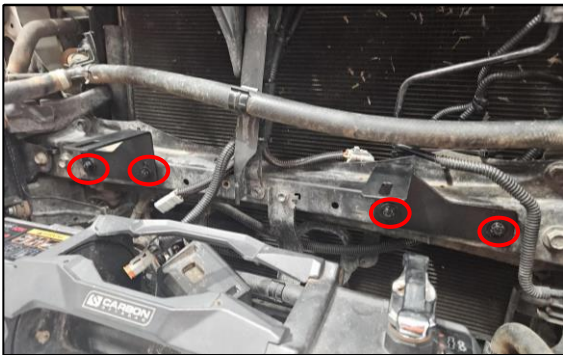
**50**

Secure the Front Grill Bracket Inside (Item 66,67) to the vehicle at the points shown in the picture using M6 bolts (M6x20x1.0), spring washers, and flat washers.

Repeat for the opposite side.

**51**

Attach the inner front grill bracket to the outer bracket using eight M8x1.0x20 bolts, along with flat washers and flange nuts, as shown.

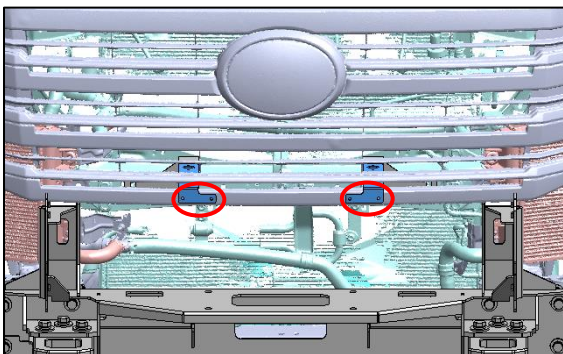
**52**

Use a 4 mm drill to make a hole at the bottom of the vehicle's Front Grill to attach the Front Grill to the Front Front Grill Bracket Outside , Using M5 bolts (M5x15) and flat washers .

FITTING PROCEDURE

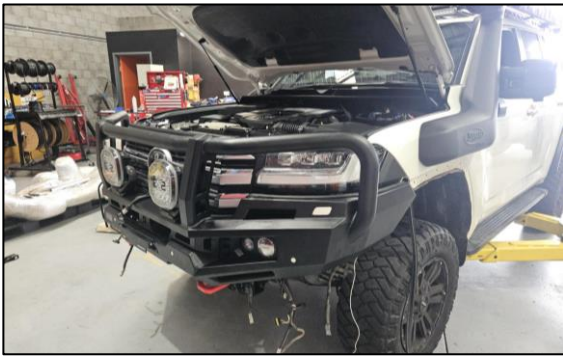

53 Lift the bull bar into position and align it with the chassis mounting holes

**** If a bull bar assist lift isn't available, it's advised that two people handle this task to prevent injury or damage to the vehicle and its parts.**

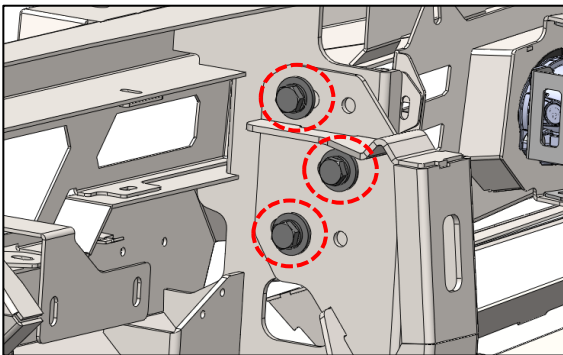

54 Lift the bull bar into position and align it with the chassis mounting holes. Secure it in place by using three M12 bolts (M12x1.5x35), along with spring washers, flat washers, and hex nuts.

**** Do not fully tighten at this stage, as the component will need to be removed in the next step.**

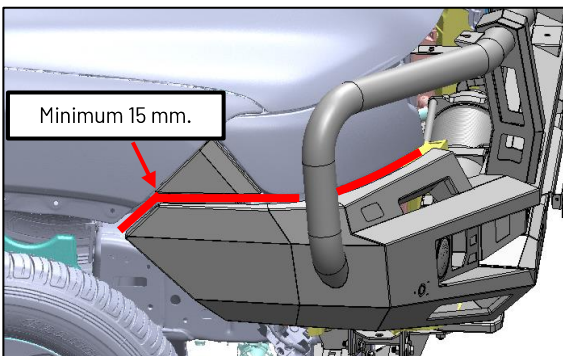

55 Align the bull bar so that there is a **15 mm minimum gap** between the car and the wing return of the bar, with the end of the wing in line with the wheel arch. Centralize the bull bar to the vehicle body, and lightly tighten the lower bolt on each side to allow for final adjustments to the correct position.

Tighten all bolts once the final position is achieved.

Note: There is limited space to access the bolts with a torque wrench.

Ensure all bolts are tightened according to the torque specifications provided on page 9.

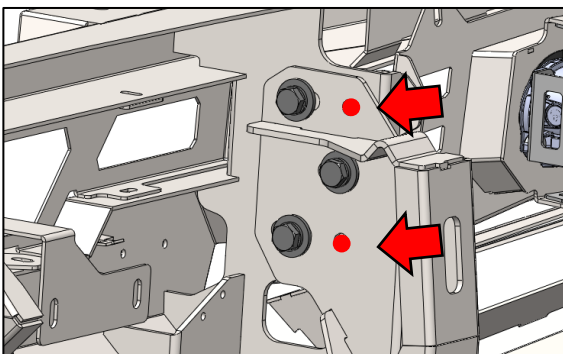

56 Mark the location of the bullbar holes on the mounting bracket as shown in the picture.

Remove the bullbar, then drill two 10 mm holes through the mounting bracket.

After drilling, deburr the edges, apply rustproof paint, and reinstall the bullbar as per the current instructions.

FITTING PROCEDURE

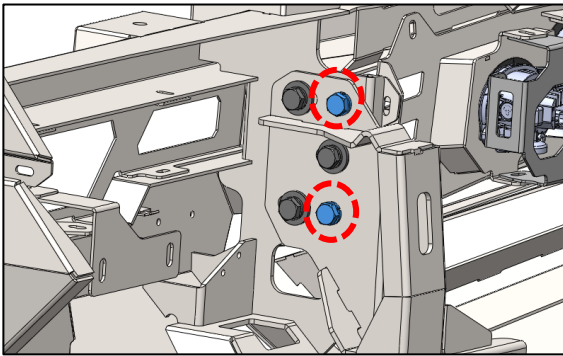

- 57** After reinstalling the bullbar, use four M10 bolts (M10×1.25×35) together with spring washers, 20 mm OD flat washers, and hex nuts to secure them through the holes drilled in the previous step.

Ensure all bolts are tightened according to the torque specifications provided on page 9.

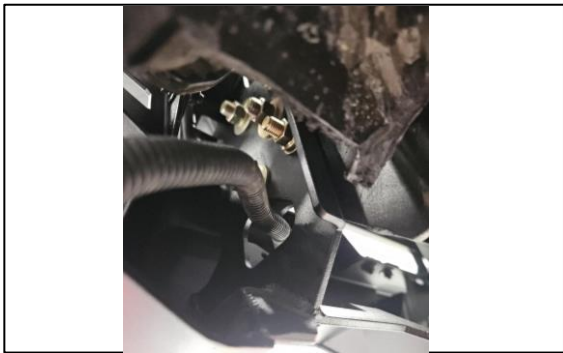

- 58** Pass inner parking sensor looms through hole in bullbar on both sides.

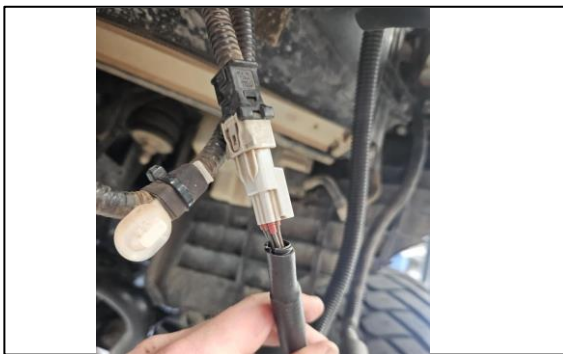

- 59** Plug parking sensor looms into OE bumper loom attached to grill.



- 60** Plug fog lamps in using OE bumper loom.

FITTING PROCEDURE



61 Reattach hoses to headlamp washers.

Cable tie looms neatly up behind the bulbar in a position that doesn't strain the looms.



62 Cable tie looms neatly up behind the bulbar in a position that doesn't strain the looms.



63 Install 2x M8x1.25x4T cage nuts into the Chassis Support Bottom .

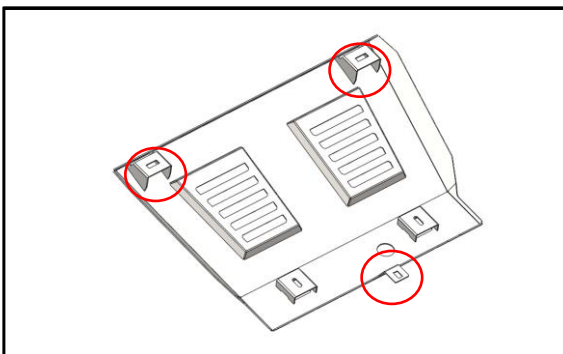

64 Install 3x M8x1.25x3.2T cage nuts into the Radiator Plate Bottom.

FITTING PROCEDURE



- 65** Install the Radiator Plate Bottom as follows :
- For the bottom position, use two spacers, hex bolts M8x30x1.25 , spring washers, and flat washers.
 - For the top position, use hex bolts M8x25x1.25 , spring washers, and flat washers.



- 66** Install the Radiator Plate Bottom as follows :
- For the top position, use two hex bolts M8x30x1.25, spring washers, and flat washers.



- 67** Install the Radiator Plate Top as follows :
- For the bottom position, use two spacers, hex bolts M8x30x1.25 , spring washers, and flat washers
 - For the top position using three M6 bolts (M6x1.0x20), spring washers, and flat washers.



- 68** Install M8x1.25x4T cage nuts into the Chassis Support Chassis Support Outside.

FITTING PROCEDURE

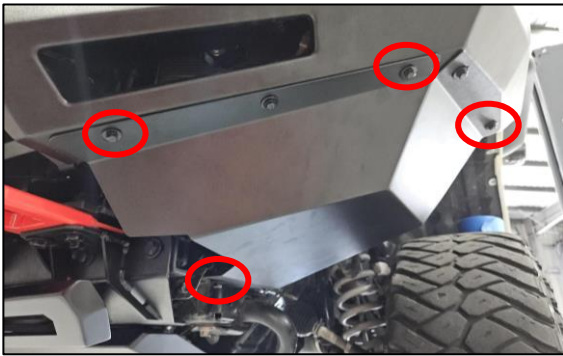

- 69** Attach the Side Plate to the bullbar using Three M6 bolts (M6x1.0x20), spring washers, and flat washers.

At the lower mounting position, use M8x1.0x30 bolts with spring washers and flat washers..

Repeat for other side.



- 70** **wheel arch liner trimming.**

Using the rear bottom folded edge of the side plate as a guide, mark a line using a visible marker or masking tape across the front face of the wheel arch liner.

Remove the side plate.

Using a multi-tool or similar, cut along the marked line on the front face of the wheel arch liner.



- 71** Attach the side plate to the bullbar at the outer mounting position using five M6x1.0x20 bolts, spring washers, and flat washers.

At the lower mounting position, use M8x1.0x30 bolts with spring washers and flat washers.

Repeat for other side.



- 72** Plug OE bumper loom (parking sensors, camera, radar) back into position.

FITTING PROCEDURE

73 Plug main headlamp washer hose back into position.



74 Reinstall front under bonnet cover.



75 Reconnect battery.

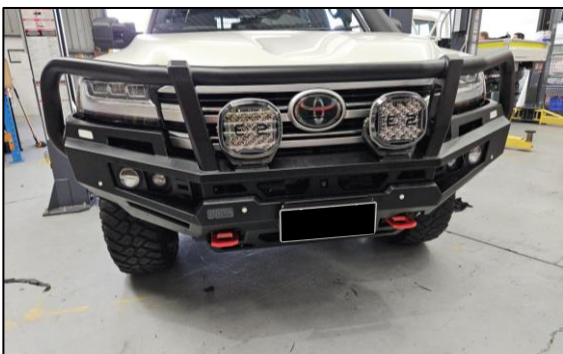

76 Check that all lamps are functioning as intended and verify proper operation of the winch.