

VEHICLE Ford Ranger - PY 2022+ (XLT, Sport, Wildtrak, Platinum)
Volkswagen Amarok - NF 2022+

PRODUCT Recovery Point

PRODUCT CODE RPRAN03

NOTE During recovery always use both recovery points

Hardware Supplied:

- 2 x M10 x 1.5P Nut/ Centre nut
- 2 x M6 x 1P Nut/ nutsert
- 2 x M12*P1.75 RH*120L Hexagon bolts half thread (Ø19)
- 2 x M12*P1.75 RH nylon nuts 19*12
- 4 x M12 washer Ø32*Ø13.2*3.0t
- 8 x M12 washer Ø28*Ø13.2*2.0t
- 4 x M12*P1.75 RH*50L Hexagon bolts half thread (Ø19)
- 4 x M12 spring washer Ø20.5*Ø12.5*2.6t

Tools Required:

- General Hand Tools
- Sockets and Spanners

Component List:

- 1 x LHS Main Body
- 4 x Side Mount Plate
- 2 x Lower Mount Body
- 2 x Centre Gusset
- 1 x LHS I/Cooler and Undertray Mount
- 2 x Crush Tube
- 1 x LHS Rail Spacer
- 1 x RHS Main Body
- 1 x RHS I/Cooler and Undertray Mount
- 1x RHS Rail Spacer

ASSEMBLY IMAGE

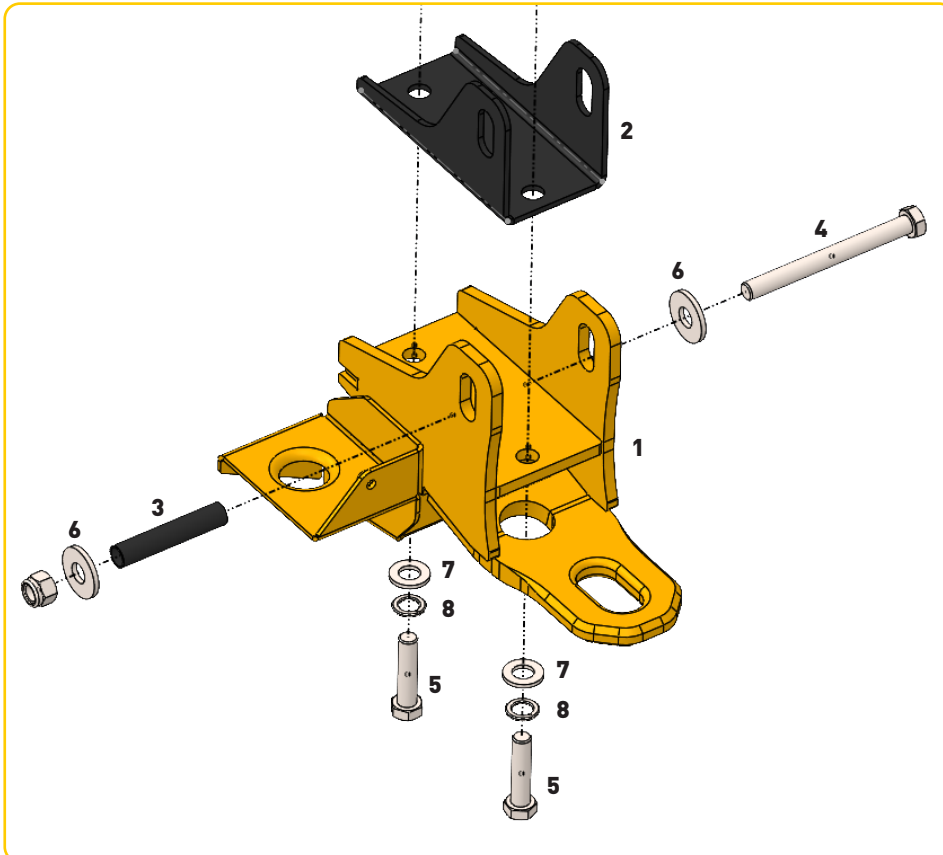

ITEM	DESCRIPTION	QTY
1	Main Body Recovery Point	2
2	Rail Spacer	2
3	Crush Tube	2
4	M12*p1.75*120L Bolt	2
5	M12*p1.75*50L Bolt	2
6	M12*Ø32*3t Washer	4
7	M12*Ø28*2t Washer	4
8	M12 Spring Washer	4
9	M12 Nyloc	2

VEHICLE Ford Ranger - PY 2022+ (XLT, Sport, Wildtrak, Platinum)
Volkswagen Amarok - NF 2022+

PRODUCT Recovery Point

PRODUCT CODE RPRAN03

NOTE During recovery always use both recovery points

1. Position vehicle to allow easy access to underneath the front chassis rails.

2. Remove front bash plate.

3. Starting with the LHS, remove the 10mm bolt which connects the factory tow point to the intercooler shroud and retain.
See figure 1.

4. Remove the two M12 bolts retaining the factory tow hooks to the bottom of the chassis.
See figure 2.

5. Remove the factory tow points.

6. Offer the Roadsafe Rated Recovery Points up to the chassis rail and loosely secure using the supplied M12 bolts, spring washers and washers.
See figure 3.

7. Insert the crush tub into the chassis rail and secure the recovery point to the chassis rail through the crush tube using the supplied ### bolt, Spring washer, washers and nyloc nut.
See figure 3.

8. Secure the intercooler shroud to the recovery point using the 10mm bolt retained in step 3. Tighten and torque all bolts to the recommended torque values.

9. On the RHS, repeat steps 3 to 9.
Note: If the vehicle is fitted with the factory bumper, the bumper and lower lip of the bumper will need to be trimmed accordingly. Where the opening in the bumper is for the factory tie down point, there is a symmetrically opposing mold detail. This can be used as a stencil and will need to be removed.
See bumper image

10. Refit bash plates to vehicle

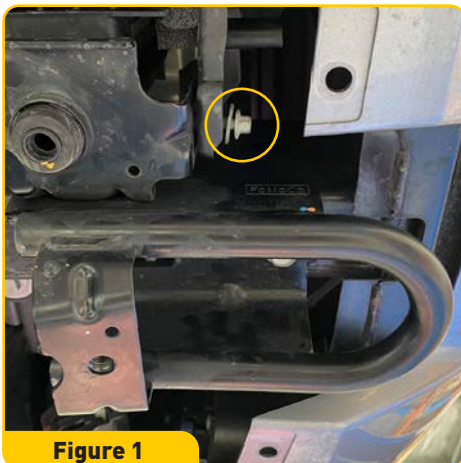

Figure 1

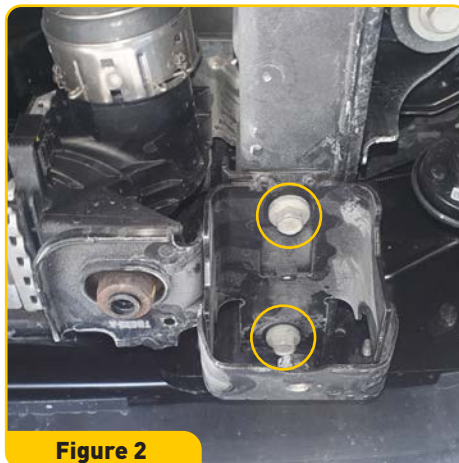

Figure 2

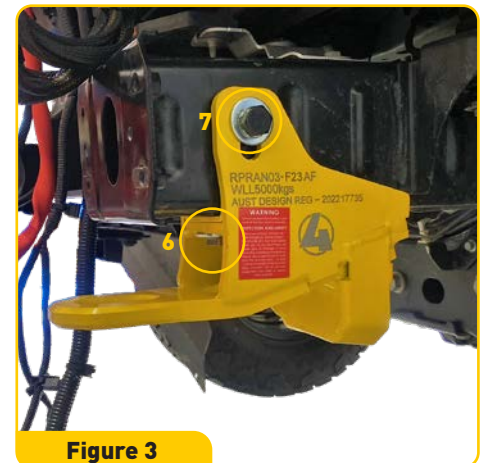

Figure 3



Bumper Image

Torque Specs

	8.8	10.9	12.9
M10	41-60 Nm	59-85 Nm	65-94 Nm
M12	71-105 Nm	102-150 Nm	114-164Nm
M14	112-168 Nm	161-240 Nm	182-265 Nm
M16	175-260 Nm	250-371 Nm	282-406 Nm