



SAFARI R-SPEC SNORKEL

SS10R

01/04/15

ITEM	DESCRIPTION	QTY	PART NO.
1	BODY - SNORKEL	1	470-133-000R
2	3" AIR RAM ASSEMBLY	1	000-135-050
3	BRACKET - UPPER MOUNTING	1	470-032-000
4	ADAPTOR - DUCT	1	470-023-200
5	HOSE - SILICONE - 82mm ID x 60mm	1	000-806-250
6	CLAMP - HOSE - 70/90	2	000-908
8	CLIP - BODY - PLASTIC	3	000-960
9	SCREW - S/T - 4.2 x 13mm	3	000-951
10	BOLT - HEX - 6mm x 1.0 x 14mm	2	000-002-100
11	WASHER - FLAT - 6mm	3	000-301
12	WASHER - STAR - 6mm	3	000-304
7	BOLT - HEX - 6mm x 1.0 x 16mm	3	000-002-100
13	STUD - S/S - 8mm x 1.25 x 25mm - O/L	4	000-110
14	WASHER - BODY - 8mm x 30mm	5	000-311-300
15	WASHER - STAR - 8mm	1	000-305
16	BOLT - HEX - 8mm x 16mm	1	000-011
17	NUT - NYLOC - 8mm x 1.25	4	000-205-300
18	TEMPLATE	1	470-017-000
19	TAPE - FOAM - 25mm x 300mm	1	000-434-030
20	HOSE CLAMP- SIZE 48 (BLACK)	1	000-918/B

WARNING!!

**IT IS AN INSTALLER
RESPONSIBILITY TO VERIFY
ALL COMPONENTS, AND
PARTICULARLY THE
TEMPLATE ARE CORRECT,
BEFORE STARTING ANY PART
OF THE SNORKEL
INSTALLATION.**

**(CHECK TEMPLATE AGAINST
SNORKEL BODY)**



SAFARI R-SPEC SNORKEL

SS10R

NISSAN PATROL / FORD MAVERICK
with vertical pre-cleaner

TD-42 DIESEL (4.2L) 1990-94
TB-42 PETROL (4.2L) ALL
RB-30 PETROL (3.0L) ALL

Fitment to: Left hand side.

Fitting time: Diesel approximately 105 minutes.
Petrol carburetor approximately 120 minutes.
Petrol EFI approximately 90 minutes.

Special Tools: Longer Arbour bit for hole saw.
89mm hole saw.
Wax and grease remover.
Heat gun.
Tin snips.

TD-42 Diesel Instructions:

1. Remove the plastic guard liner from the left hand front wheel arch. Using a heat gun, remove the "PATROL" / "MAVERICK" badge from the guard. Wash off the excess glue with wax and grease remover. Remove the pre-cleaner and connecting duct from the engine bay.

On later model vehicles, a deflector plate is located on the wheel arch side of the air inlet hole. This will need to be removed. To do this, drill out the 4 spot welds using a 6mm drill bit. Then from underneath the wheel arch, wedge a medium size screwdriver between the deflector flange and the engine bay wall. Tap around the flange using a hammer until the deflector drops out.

2. Tape the template in position on the upper rear corner of the guard. Using a felt pen, mark the hole positions then remove the template.
3. Drill a 4mm pilot hole for each of the holes. Open the 5 mounting holes out to 16mm using a step drill. Open the front hole to 6mm, dropping the drill to a horizontal position whilst drilling. This will allow the holesaw to be used at the correct angle. Then, using an 89mm hole saw with a 150mm long arbour bit, cut the main hole. The hole saw should be horizontal while cutting, and the lower edge of the hole should be approximately 18mm away from the outer guard fold. The hole saw will bottom out while cutting this hole, so you will need to stop and trim some of the metal out of the centre of the hole using tin snips. This will then allow you to finish cutting the hole easily. After drilling and cutting, deburr all the holes to leave a smooth edge.
4. Screw the 4 stainless steel mounting studs into the relevant holes in the back of the snorkel. Fasten the upper mounting bracket to the snorkel body using 2, 6mm bolts and washers. Sit the snorkel in position on the car and mark the 3 upper mounting holes on the "A" pillar.
5. Remove the snorkel and drill the 3 holes to 8mm. Paint both the upper and lower holes with appropriate paint to prevent rust. Insert the plastic body clips into the upper holes.
6. Place the snorkel in position on the vehicle and secure using appropriate hardware. For best results, tighten the lower mounting positions before securing the upper mounting screws.
7. Remove the lid, element and connecting duct from the pre-cleaner. Turn upside down and place flat on the ground. Open out the 3 mounting holes to approximately 1/2" using the step drill. Using silicone, seal the plastic base to the metal body. Also seal the rubber water valve as this is no longer required. Place a bead of silicone around the inside of the connecting duct and the join in the duct. Refit the duct to the pre-cleaner body.
8. Slide the 3 1/4" connecting hose onto the snorkel snout. Slide 2, 70/90 hole clamps onto the hose. Sit the alloy casting in position in the engine bay. The snout should push into the connecting hose. Fasten by using 3, 6mm x 16mm bolts with washers, screwed into the existing holes in the body work. Centralise the connecting hose and secure in place with the hose clamps.

9. Fit a ring of foam tape to the air cleaner snout to act as a seal. Place a bead of silicone around the snout of the pre-cleaner. Slide the pre-cleaner into position against the casting and fasten in place using the original hardware. Refit the connecting duct to the air cleaner and seal the joint with silicone.
 10. Place the air ram on top of the snorkel and secure with the clamp provided.
 11. Refit the guard liner to the wheel arch.
- * A small bead of silicone may be placed around the top and front edges of the snorkel body to seal it against the vehicle.
-

TB-42 / RB-30 Petrol Instructions (Carburettor Models) :

Follow instructions for TD42 numbers 1 through 6.

7. Remove the plastic clip from the flat flange on the air ducting. Sit the flange on the first stage of the air ducting against the alloy casting. The front and lower hole positions will line up. The third hole will have to be marked and drilled to 8mm.
 8. Slide the 3 1/4" hose onto the snorkel snout. Slide 2, 70/90 hose clamps onto the hose. Sit the alloy casting in position on the inner guard. The snout should push into the connecting hose. Place a bead of silicon around the sealing face of the air duct. Match the duct flange to the alloy casting flange, and bolt both to the vehicle, using the factory hole positions in the body work. Centralise the connecting hose and secure in place with the hose clamps.
 9. Refit the original air ducting, taking particular care to seal each join with silicone. Hose clamps should be fitted where necessary. The rubber water trap on the pre-spinner must be permanently sealed, as it is no longer required. Likewise, the cold start butterfly assembly must be siliconed shut to prevent water seepage. The vacuum hose leading to this assembly will also need to be blocked off.
 10. Place the air ram on top of the snorkel and secure with the clamp provided.
 11. Refit the guard liner to the wheel arch.
- * A small bead of silicone may be placed around the top and front edges of the snorkel body to seal it against the vehicle.

TB-42 Fuel Injected Model Instructions:

Follow instructions for TD42 numbers 1 through 6.

7. Remove the plastic clip from the flange on the plastic connecting duct. Sit the flange against the alloy adapter. The front and lower hole positions will line up. The third hole will have to be marked and drilled to 8mm.
 8. Slide the 3 1/4" hose onto the snorkel snout. Slide 2,70/90 hose clamps onto the hose. Sit the alloy casting in position on the inner guard. The snout should push into the connecting hose. Place a bead of silicon around the sealing face of the air duct. Match the duct flange to the alloy casting flange, and bolt both to the vehicle, using the factory hole positions in the body work. Centralise the connecting hose and secure in place with the hose clamps.
 9. Place a bead of silicon around the air cleaner snout and refit it to the vehicle.
 10. Place the air ram on top of the snorkel and secure with the clamp provided.
 11. Refit the guard liner to the wheel arch.
- * A small bead of silicone may be placed around the top and front edges of the snorkel body to seal it against the vehicle.



4X4 ENGINEERING

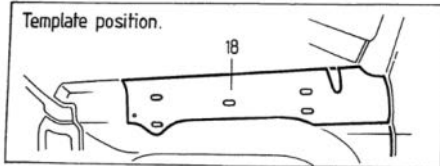

SAFARI SNORKEL GQ Patrol / Ford Maverick - Petrol models.
Part No: **SS10R**

18/3/94

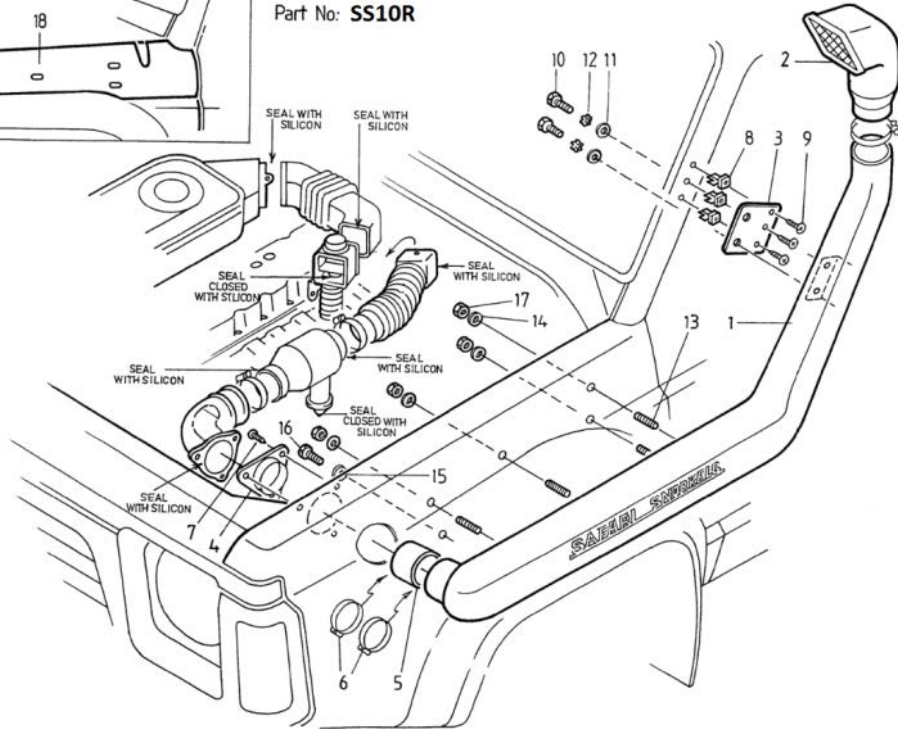

SAFARI

4X4 ENGINEERING

