

# Fitting Instructions #TRC8470IS

Toyota Hilux 4WD 2005 - On

## Adjustable Camber/Caster Upper Control Arms



1. Before beginning any alignment work, always check for loose or worn parts, correct tyre pressures, and odd tyre wear patterns. Replace any loose or worn parts before setting alignment;
2. Raise the vehicle by the chassis and support it with jack stands. Remove the front tyre and wheel assemblies.
3. Loosen the nut on the upper arm-to-frame mounting bolt and remove bolt-holding ABS wiring from the upper arm.
4. Remove the split pin and nut holding the original equipment ball joint to the spindle. Break the taper between the ball joint stud and spindle and remove the ball joint from the spindle. Support the spindle so no strain is applied to ABS wiring or brake lines.
5. Remove the nut and washer from the long arm-to-frame mounting bolt and remove the bolt and arm.

**Note:** To provide clearance, additional components in the engine compartment may need to be removed.

6. Using supplied grease only, lightly coat the ends of the bushing.
7. Install the control arm on the vehicle.

Note: The ball joint comes preinstalled and torqued to spec in a position suited for a 50mm lifted vehicle. Please see the alignment tuning guide on the next page if you wish to modify the wheel alignment settings.

**Important:** The Toyota-supplied washers are cupped and should be installed as per below, along with the supplied new washers. Torque bolt-nut to 115 Nm.

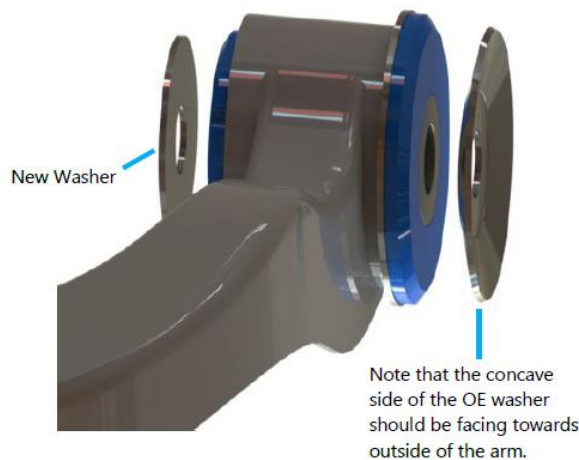

Unlike bonded or rubber bushings, SuperPro bushings pivot freely and so can be torqued at full droop.

8. Insert the ball joint stud into the spindle, install the supplied castle nut and torque to 110Nm. Tighten further until the supplied split pin can be installed.
9. Re-attach the ABS wiring bracket to the arm using the supplied nut and stud. Check the length of the ABS cable to **ensure the cable isn't too tight**.
10. Re-install the tyre and wheel assembly. Lower the vehicle and check for clearance and wheel align. Optimum camber, caster and setback can be set by the OEM lower control arm camber pins.

# Fitting Instructions #TRC8470IS contd.

Toyota Hilux 4WD 2005 - On

Adjustable Camber/Caster Upper Control Arms



## Alignment Tuning Guide

The unique advantage of the SuperPro adjustable ball joint system, offers fine tuning of alignment settings or to adjust the clearance on either the coil spring at full droop or the sidewall of oversize tyre and wheel packages at ride height. This is achieved by sliding the upper ball joint outwards on either or both sides. After adjustment re-tension ball joint nut to 143Nm.

Below outlines how to fine-tune the wheel alignment for your vehicle using the SuperPro adjustable upper control arms.

A general rule of thumb on this Toyota is that 8mm of ball joint movement roughly equals a 1-degree change in camber or caster.

The ball joint can be rotated through 12 fixed positions by re-positioning the hex on the ball joint into the double-hex washer, as shown to the right.

Using the previously mentioned rule of thumb, the below ball joint positions will roughly result in the following changes to the alignment relative to the centre.

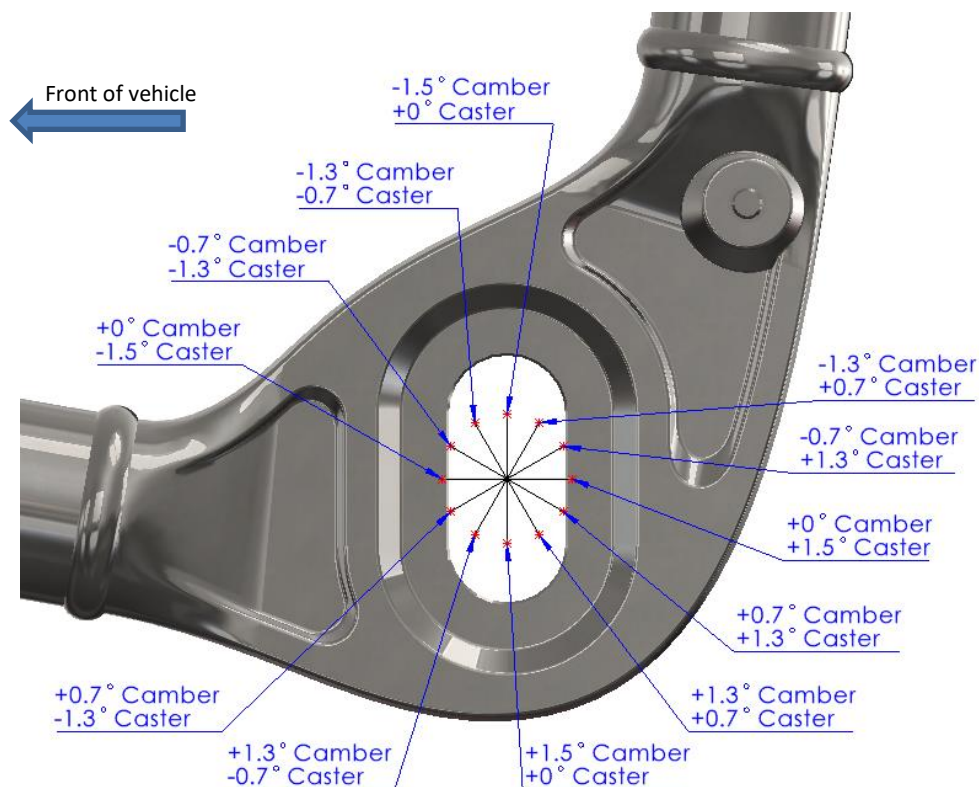
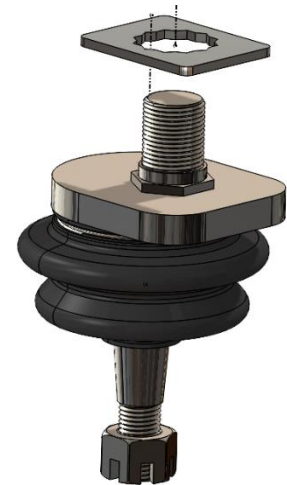

In conjunction with rotating the ball joint, the ball joint can slide in and out in the slot, which allows for +/- 1.5 degrees of additional camber adjustment.

**Please note: The ball joint bolt top nut needs to be torqued to 143Nm.**

# Fitting Instructions #TRC8470IS contd.

Toyota Hilux 4WD 2005 - On

Adjustable Camber/Caster Upper Control Arms

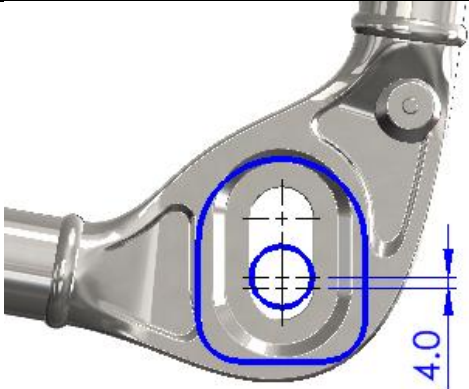
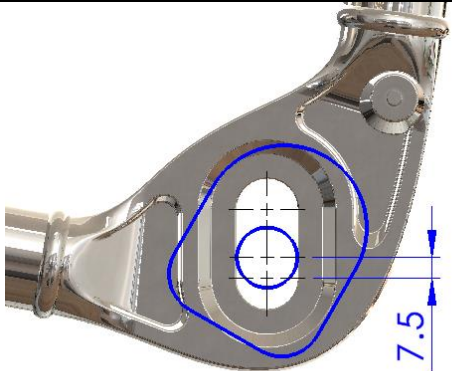

Recommended settings for 50mm lift (2")	Recommended settings for 75mm lift (3")
	
<p>Position the ball joint pointing straight inwards and slide the ball joint 4mm from the outside.</p>	<p>Position the ball joint to the first position angled rearward and slide the ball joint 7.5mm from the outside.</p>
<p>This configuration roughly equates to the following changes over the OE UCA:                      Camber: -0.5 deg                      Caster: +1.8 deg</p>	<p>This configuration roughly equates to the following changes over the OE UCA:                      Camber: -0.7 deg                      Caster: +2.6 deg</p>