

Remove the original rails covers whit care.

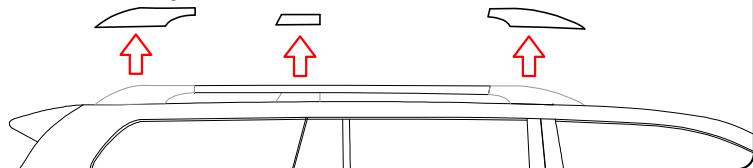

Remove the original bolts and original rails racks.

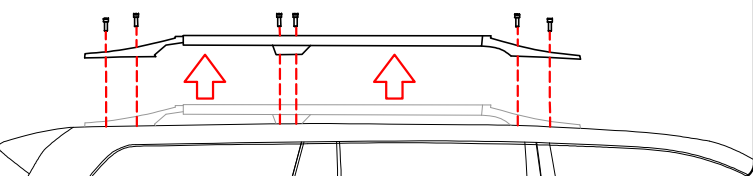

If it does't have the original rails racks, remove the 6 hole covers to reveal the threaded holes.

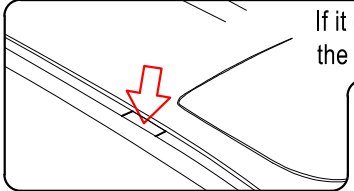

1- Use SEALANT around all roof holes before place brackets to protect and seal.
2- Clean the sealant excess after placement of roof - brackets.

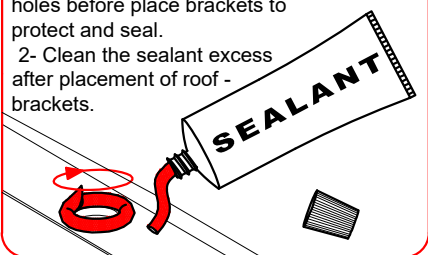

Fit side under rails with Alen cap M8 in original holes and tighten.

- 20 M8 X 16 Alen cap. X12
- 26 M8 Washer X12

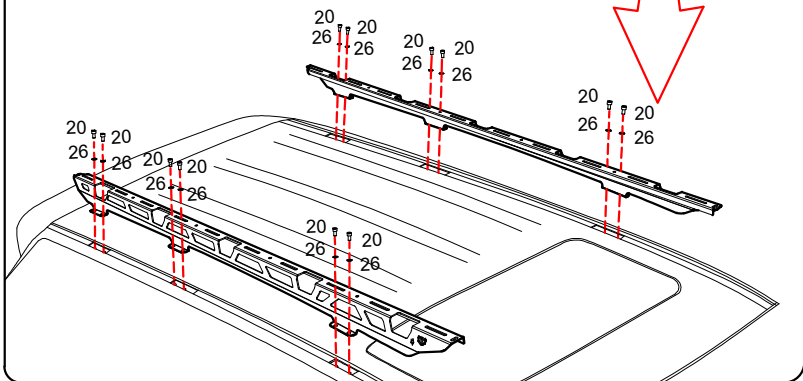

TOYOTA PRADO 150 103630



TMX RR 103629 BRACKET BOLT KIT

Item N°	Part	Description	Qty
18	M8 1.25 flange nylock nut		8
19	M8 1.25 X 25 Alen cap		8
26	M8 washer		20
20	M8 1.25 x 16 Alen cap		12

- 19 M8 X 25 Alen Cap X 8
- 26 M8 Washer X 8
- 18 M8 Nylock Flange nut X 8

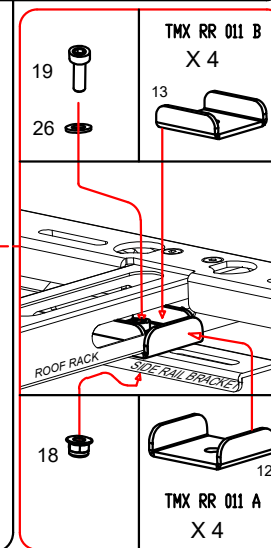
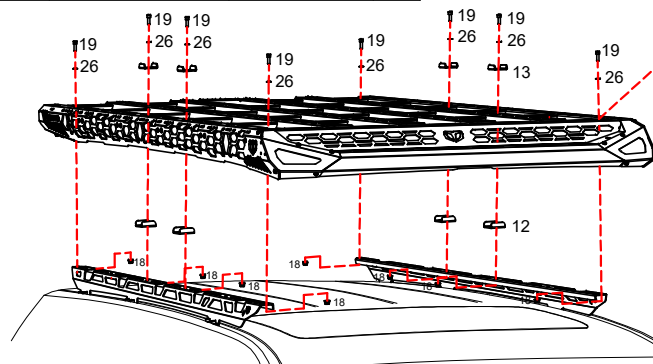

Tighten all M8 Allen cap bolts and M8 nuts using 6mm Allen key and 13mm Wrench.

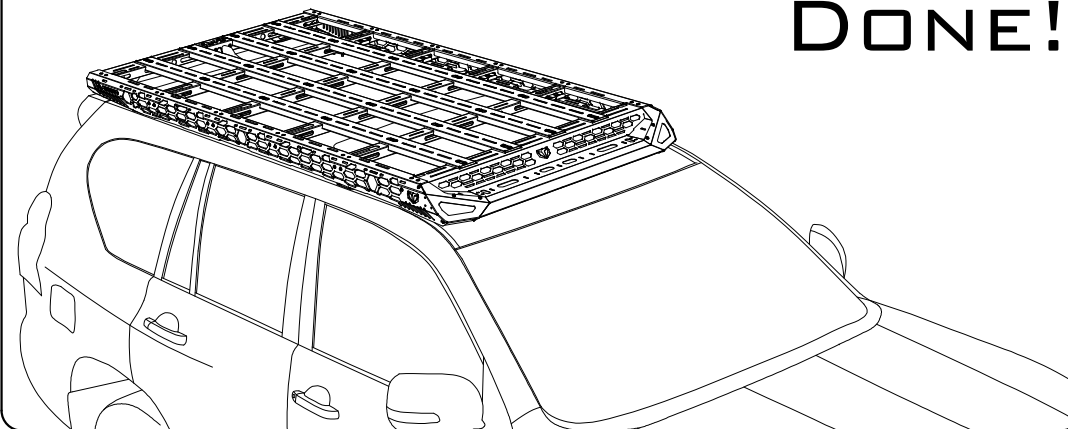

DONE!