



## SAFARI R-SPEC SNORKEL

# SS390R

01/04/15

ITEM	DESCRIPTION	QTY	PART NO
1	BODY – SNORKEL	1	830-133-500R
2	3" AIR RAM ASSEMBLY	1	000-135-050
3	BRACKET - UPPER MOUNTING	1	830-032-000
4	BOLT - HEX - 6mm x 1.0 x 14mm	3	000-002-100
5	WASHER - FLAT - 6mm	3	000-301
7	BOLT - HEX - 6mm x 1.0 x 16mm	3	000-002
8	WASHER - FLAT - 6mm x 16mm	3	000-310
9	NUT - NYLOC - 6mm	3	000-204
10	STUD – S/S 8mm x 1.25 x 25mm - O/L	6	000-110
11	WASHER - BODY - 8mm x 30mm – S/S	6	000-311-300
12	NUT - NYLOC - 8mm x 1.25mm – S/S	6	000-205-300
13	RIVET - POP - 4mm x 12mm	12	000-958
14	SCREW - S/T - 4.2mm x 13mm – S/S	4	000-951
15	CLAMP - HOSE - 60/80mm	2	000-907
16	PLUG - 70mm	1	000-959-200
17	EDGING - RUBBER - 400mm	1	000-953-040
18	BRACKET - AIR CLEANER MTG (REAR)	1	830-031-500
19	BRACKET - AIR CLEANER MOUNTING	1	830-031-000
20	ADAPTOR - AIR CLEANER ENTRY	1	830-023-500
21	DUCT – CONNECTING	1	830-124-500
22	TEMPLATE	1	830-017-500
23	CLIP- BODY (PLASTIC)	2	000-960
24	BRACKET-SWITCH RE-LOCATION	1	830-089-500
25	RIVET POP - 4.8mm x 21mm	3	000-958-400
26	HOSE CLAMP - SIZE 48 (BLACK)	1	000-918/B



## SAFARI R-SPEC SNORKEL

# SS390R

---

**LAND ROVER DISCOVERY (300 SERIES)**

**TURBO DIESEL (2.5L)  
V8 PETROL (3.9L)**

---

**Fitment to:** Left hand side

**Fitting time:** Approximately 120 minutes

**Comments:** Suits TDI/V8 with or without A.B.S.

**Special Tools:** 86mm holesaw                      89mm holesaw  
Pop rivet gun                                      Air hacksaw  
Step Drill    Loctite 243 (thread lock)

---

**Prior to commencing the installation, it is the installer's responsibility to verify that all components and particular the template (item 22) are correct.**

---

### **Instructions:**

1. Remove the left front guard liner and air cleaner assembly. On petrol vehicles the air flow meter and rubber duct from the inlet manifold must also be removed.
2. Locate the template on the upper rear corner of the guard and mark the hole positions using a felt pen. Remove the template and drill a 4mm pilot hole for each position. Open the 6 mounting holes to 16mm using a step drill. Drill the main hole to 86mm using a holesaw. Deburr all holes to leave a clean edge.
3. To locate the inner hole, measure back from the headlight support panel 450mm, then down from the bottom edge of the guard flange 60mm. This hole should be located in the centre of the round bulge in the side of the engine bay. Drill a 4mm pilot hole, then open the hole out using a 89mm holesaw. Deburr to leave a clean edge.
4. Paint all holes using a suitable touch up paint.

5. Apply Loctite 243 to each of the stainless steel mounting studs (item 10) and install the studs finger tight into the snorkel body (item 1) mounting inserts. Bolt the upper mounting bracket to the snorkel body with hex bolts (item 4).
6. Position the snorkel body on the vehicle and secure using 8mm nyloc nuts and body washers supplied. Mark holes for "A" pillar bracket remove bracket and drill holes. Deburr and paint holes. Use the 4mm pop riverts to fasten bracket to "A" pillar. Position the air ram on the top of the snorkel body and tighten the clamp.
7. Remove the air cleaner lid, mounting plugs and filter element from the air cleaner assembly. Locate the adaptor casting on the lower LHS front corner of the air cleaner body and mark the main hole position using a scribe. Remove front three ribs from air cleaner body to obtain flat surface. Use an air hacksaw to cut out the hole. Smear silicone sealant on the sealing surface of the adaptor casting then fasten it to the cleaner body using 4mm pop rivets.
8. Cut off the 2 locating pins on the front of the air cleaner body. Locate the large mounting bracket on the front face of the body and fasten in place with 4mm pop rivets.
9. Remove air filter inlet by removing flange clip inside air filter housing and pull out air inlet extension.
10. Use the 70mm blank off plug to fill the original intake hole. The plug should be sealed in place using silicone and fastened using 2 x item No. 14. The drain holes in the bottom of the air cleaner body should also be sealed using silicone.
11. Position the air cleaner body in the vehicle. The pins on the front mounting bracket locate in the original mounting bushes. When in the correct position, the pins should push approximately 1mm through the bushes.
12. Mark the new rear mounting hole position through the large hole in the bottom of the air cleaner onto the inner guard. Remove the air cleaner and drill the hole to 12.5mm.
13. Refit the mounting plugs into the air cleaner body then relocate the air cleaner body into the vehicle. Fit the rear mounting bracket to the second mounting plug. Mark the 3, bracket mounting hole positions on the inner guard. Remove the air cleaner body from the vehicle and drill the 3 holes to 7mm. Bolt the rear bracket in place using item Nos. 5, 7, 8 and 9.
14. Fit the rubber edging around the inner hole. Smear silicone to the inside of connecting duct at both ends. Slide the long end of the connecting duct onto the snorkel snout and secure with a 60/80 clamp.
15. Re-assemble the air cleaner, then position it in the vehicle. Fasten the end of the connecting duct to the adaptor casting using a 60/80 clamp.

**N.B: PETROL VEHICLES**

The rubber duct for between the air flow meter and inlet manifold will have to be shortened as shown in diagram.

16. Using bracket supplied in kit to relocate bonnet switch as shown in diagram, mark holes with a felt pen and drill 2 x 8mm holes. Install the plastic body clips and secure the switch relocation bracket with 2 x self taper screws. Reposition the ABS brake pipe to clear mounting bracket.
17. Refit guard liner and use 3 large headed pop rivets supplied to fasten liner.

**N.B: It is the installer's responsibility to ensure that all connections are watertight.**

# SAFARI

## 4X4 ENGINEERING

Model No: **SS390R** 18/12/97  
Description: LANDROVER DISCOVERY TDI  
Sub Assembly: SAFARI SNORKEL

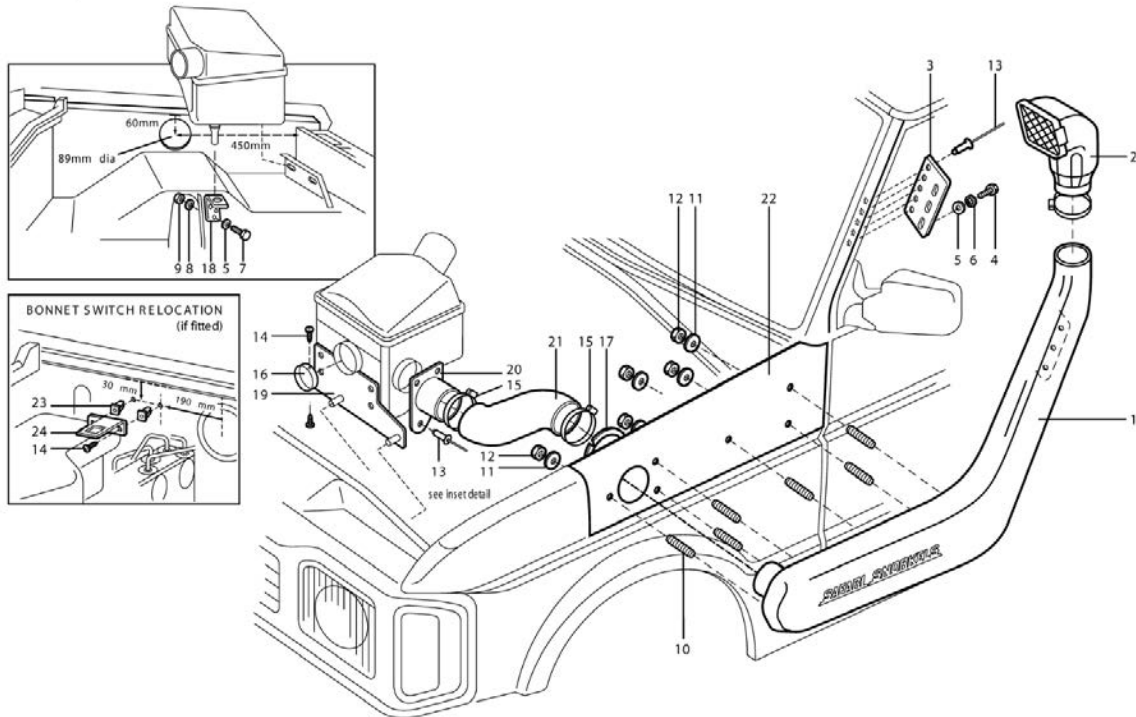

# SAFARI

## 4X4 ENGINEERING

Model No: **SS390R** 18/12/97  
 Description: **LANDROVER DISCOVERY 3.9 V8**  
 Sub Assembly: **SAFARI SNORKEL**

