



# GP50 Owners Manual

Serial numbers GP501001 onwards



[www.GigglepinWinch.com](http://www.GigglepinWinch.com)

[Shop@Gigglepin4x4.net](mailto:Shop@Gigglepin4x4.net)

+44 (0)1732 463600



# This is your GP50!

Serial Number \_\_\_\_\_

TopHousing Ratio \_\_\_\_\_

Drum Length

Short

Standard

Long

Motors \_\_\_\_\_

Solenoid \_\_\_\_\_

Hurricane Fitted

Yes

No

MBS Fitted

Yes

No

Notes \_\_\_\_\_

Built By \_\_\_\_\_

Build Date \_\_\_\_\_ / \_\_\_\_\_ / \_\_\_\_\_

This GP50 has been hand crafted to your personal specification.

It is ready for a life of pulling hard.

But every winch is different, so tell us about you winch story and

what you do with your GP50

**What is your Winch Adventure?**

**Let us know through our email or social media!**



GigglepinWinches



#GigglepinWinches

If you need any advice or spare parts don't hesitate to get in touch

[Shop@Gigglepin4x4.net](mailto:Shop@Gigglepin4x4.net)

+44(0) 1732 463 600





# Table of Contents

<b>1. Introduction</b>	<b>Page 1-3</b>
a. What's in the Box	1
b. How do I Fit my GP50	2
<b>2. Application information</b>	<b>Page 3-7</b>
a. Rope	3
b. FreeSpool	4
c. Using Your GP50	4
d. Electrical	5-6
e. Brakes (including MBS)	7
<b>3. Rigging and Winching Advice and Tips</b>	<b>Page 8</b>
a. Common Winch Hand Signals	9
b. Winch Remotes and Radios	9
<b>4. Winch Maintenance</b>	<b>Page 10-11</b>
a. Maintaining Your Winch	10
b. Maintaining Your Rope	11
c. Top Tips for Your GP50	11
<b>5. Warranty</b>	<b>Page 12</b>
<b>6. Contact Information</b>	<b>Page 12</b>
<b>7. Technical Data</b>	<b>Page 15-27</b>
a. TopHousing Diagram	15-16
b. LowerHousing Diagram	17-18
c. Winch Wiring Diagram 12V	19
d. Winch Wiring Diagram 24V	19
e. Winch Wiring Diagram OverVolting	20
f. FreeSpool and Solenoid Wiring Diagram	20
g. Winch Wiring Diagram 12V Fitted With MBS	21
h. Winch Wiring Diagram 24V Fitted With MBS	21
i. Winch Dimensions – Short Drum	22
j. Winch Dimensions – Standard Drum	23
K. Winch Dimensions – Long Drum	24
l. GP50 FairLead Mounting Underwound	50
m. GP50 FairLead Mounting Overwound	50
<b>8. Glossary</b>	<b>Page 27</b>
<b>9. Ratio Information</b>	<b>Page 28</b>

# 1. Introduction

The Gigglepín GP50 competition winch has been designed and built to give you the highest levels of performance and reliability in a demanding world. Using the best materials and designs that set it apart from all of its competitors, it is the standard to which others aspire. Our winches have been built to give our end user total reliability in the toughest situations, and supply unequalled power and speed at those critical moments.

This manual will provide you with the information that you require to install, use and maintain your Gigglepín winch. These are shown below are shown throughout the manual.

**Warning** – Procedures which must be followed precisely in order to avoid risk of personal injury.

**Caution** - This calls attention to procedures which must be followed to avoid damage to winch components.

**Note** – This calls attention to methods which make a job easier or gives helpful hints.

**The GP50 should be respected and used correctly.**

**Winches are not designed to lift, support or transport personnel.**

## a. What's in the box

**Congratulations on the purchase of this GP50 Winch!**

**When you open the box you will find the following inside -**

- **GP50 built to your specification**
- **Winch Activation Pack** which includes -
  - On/off Switch
  - Switch Cover for FreeSpool Operation
  - Air Solenoid
  - Connectors
  - 6 Metres of 6mm Airline
  - PTFE Tape
- **Instruction Manual**
- **Sticker Pack**
- **T-Shirt**



## b. How do I fit my GP50

The GP50 has 18 symmetrical M12 mounting bolts giving it superior winch security in the toughest of situations. When fitting your GP50 winch a minimum of six retaining bolts on one face must be used at all times.

**Note - The four missing mounting bolts and washers from the front of your winch are used to secure the winch to the shipping pallet.**

If possible Giggiepin recommend using two of the three mounting faces to hold the winch securely, and using twelve mounting bolts where possible. Giggiepin recommend the use of winch mounts made from a minimum of 8mm steel plate. Rear mounting bolts should not go into the casing more than 20mm.

**Giggiepin DO NOT recommend the use of tubular style winch mounts or wide mouth fairleads.** Your GP50 arrives fitted with two aluminium BraceBars to the rear of the winch. We recommend that the BraceBars are retained where possible, unless the rear mounting points are to be used. The GP50 is best mounted standing upright. However it can be mounted at various different angles, but we recommend this must not be less than 20 degrees from horizontal, so as not to affect gearbox operation and to prevent oil pooling in the TopHousing.

The Winch can also be mounted in a reverse position, but care must be taken to install the Fairlead and rope in the correct position.

**Caution - We do NOT recommend the winch is mounted laid flat.**

**Warning - Please remember that winch mounts need to be strong and securely fastened to the vehicle or platform. Weak or bent mounts could result in equipment failure and possible personal injury.**

### Fitting your Fairlead

You must fit the Fairlead to the correct location dependant on how your winch is installed. With the winch in the upright (Section 7, Page 50) position, the FairLead needs to be fitted to the lower front mounting points. If using the winch in a reverse position, the FairLead would need to be mounted at the top (Section 7, Page 50).

It is also very important that the 3x M8 support bolts are used (Not used on short drums).

These can be fitted in two ways -

- Drill and tap your winch mounting plate, then trim the bolt to the correct length so it does not interfere with winch rope. **Note - This is our recommended method.**
- Drill a hole through your winch mount and use the nuts and bolts supplied.

After fitting your FairLead, make sure there are no sharp edges on the mount that might damage your winch rope.

## 2. Application Information

A GP50 winch is designed to move a load at ground level or up or down an incline. It is not designed for, nor intended for hoisting.

A GP50 winch is not designed to be used to lift or move people.

A GP50 winch is for intermittent use and is not designed for continuous use.

If the winch motors become hot, allow the winch motors to cool before continuing to winch.

If the winch stalls during operation, **stop pulling! DO NOT** continue to apply power to the winch. This can damage your winch and your electrical system.

Re-evaluate the rigging, check for obstruction and double-line if required.



## a. Rope

GP50 Winches are designed to be operated using synthetic winch ropes (we do not recommend the use of steel cables with this winch).

The GP50 winch is designed to be used in the upright position and the rope should be installed from under the drum. This is called "Under wound".

If the winch is mounted back to front (in a reverse position) the rope will be installed over the top of the drum to allow the drum to rotate in the correct direction so the brake still works. This is called "Over wound".

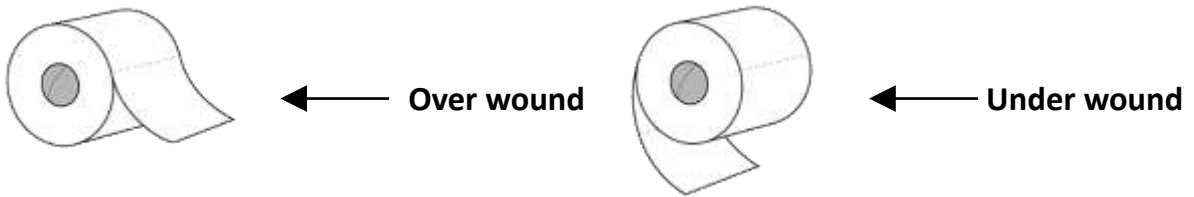

**Note - From the top = over wound. From the bottom = under wound.**

**Caution - the use of steel rope is not recommended.**

### Fitting a Rope to a GP50

The GP50 winch drum is nylon coated for durability and has a welded loop on one side.

- If the winch is fitted in an upright position, pass the synthetic rope through the Fairlead and under the drum.
- Bring the rope around the back of the drum and over the top. Then pass the end of the rope through the retaining loop.
- Tie a simple stop knot and pull tight.
- Your rope is now secure and ready to spool the rope on to the winch drum.
- When retrieving the rope in a no load situation it is often advisable to pulse the winch so the motors do not over rev.
- Be sure the rope is distributed evenly and tightly on the drum.

**Warning - Over revving when retrieving rope in a no load scenario can cause premature motor failure.**

**Caution - GP50 winches are very fast, be sure to be standing at least two metres from the winch, always wear gloves and make sure there are no loops in the rope or debris that could catch your hands.**

### Rope Care and Use

Synthetic ropes are waterproof, float and are easier to handle than steel cable, however debris can become caught in the strands, so gloves must be worn **AT ALL TIMES**.

Synthetic ropes do need to be cared for - follow these simple rules to increase rope longevity and safety

- Never use on rocks without protection.
- Avoid constant High UV exposure.
- Keep ropes clean and dry.
- Check ropes for damage before and after use.
- If the rope is damaged, pinched, frayed or defective in any way, this will reduce the load-carrying capability and should be replaced or repaired immediately.
- **ALWAYS** wear protective gloves when handling any winch rope.



## b. FreeSpool

GP50s are fitted with an air FreeSpool mechanism. The FreeSpool mechanism allows fast removal of the rope from the winch without having to engage the motors. This can be remotely controlled using switches (supplied) or remote controls (supplied separately). The winch comes supplied with an electric air solenoid control valve, switch and red safety cover for this purpose (air switches are also available if required). Follow the simple diagram for fitting the FreeSpool control solenoid and operating switch and pipe work. (Section 7, Page 20)

When mounting the switch, try to mount it in a position where it is easily seen and cannot be knocked accidentally.

When using the FreeSpool follow these simple rules to ensure positive operation -

1. Before disengaging the free spool, be sure there is no load on the winch or cable.
2. When removing cable from the drum, take care not to accidentally knot the rope.
3. After re-engaging the FreeSpool we recommend that you run the winch 'out' approximately one metre and then 'in' to allow the FreeSpool mechanism to engage fully before applying load.

**Note - Wiring diagrams can be found in Section 7 Technical data. (Page 15)**

**Warning - The FreeSpool should only be operated when the winch motors are not turning.**

**Warning - Operating the FreeSpool when the winch is under load or spinning freely could cause damage to the operating parts and cause personal injury.**

## c. Using your GP50

Gigglepin winches are very fast and powerful and require respect during use. Here are a few tips and techniques that will help you get the most from your winch.

1. Place your winch switches in a location where they are easy to use and see, also somewhere they cannot be knocked easily.
2. **NEVER** put your limbs close to the FairLead or near the winch during operation.
3. Always make sure you use a secure winching point/ground anchor.
4. Do not stall your winch, if your winch should slow down or near stalling, **STOP**. Check for obstructions under or in front of your vehicle or possible faults with your electrical system.
5. Always allow the winch to stop turning before switching in a different direction.
6. When winching, try to keep your wheels turning at the same speed as the winch. This will help aid traction and help get the most from the winch.
7. Always keep the winch line under tension this will help to eliminate the chance of over spooling or ropes becoming wrapped around the winch, which could lead to breakages or premature rope failure.
8. Do not allow the cable to 'Bunch' on the drum this could lead to the tie bars being bent or in the worst case actually breaking the winch casing and or damaging the rope.
9. Ensure power to winch is isolated before touching or handling any part of the winch.

## d. Electrical

Your GP winch comes prewired and ready to use. It only requires heavy power, heavy earth (ground) and switching wires to be connected.

**Note - Please see below for exact requirements.**

**Note - Full wiring diagrams available in Section 7.**

### 12 Volt Systems using 12v motors and solenoids

The GP50 winch requires a heavy 12v feed using a minimum of 50mm<sup>2</sup> cable. This needs to be connected to the red M8 terminal on the rear contactor and preferably via a large 500amp (continuous) cut off switch (see picture below).

The heavy earth connection needs to be a minimum of a 50mm<sup>2</sup> cable and connected to the bottom of the motors using the M8 fixings supplied. This should return to the battery for best results.

You then need to connect the red and green solenoid switch wiring. We recommend that you fit a momentary on/off/momentary on style toggle switch inside the cab within easy reach of the driver and ideally mounted next to your FreeSpool switch. A 12v switching feed is required and should be fused.

We suggest using no less than a 65amp 12v alternator and recommend using Odyssey PC1500 or PC1700 batteries, although other gel and AGM type batteries designed for high discharge are also suitable.

**Caution - Electrical systems are only as good as their connections. Use high quality cables and battery terminals. Giggiepin can supply a large range of components and premade cables for any winch install. If you are unsure of your vehicles suitability please contact Giggiepin.**

**Caution - Beware of smaller 100amp kill switches as they can burn out.**



**Giggiepin recommend using a Durite 500 amp Rated Isolator & Removable Key (0-605-50)**

### 24 Volt Systems using 24v motor and 24v solenoids

The GP50 winch requires a heavy 24v volt feed using a minimum of a 50mm<sup>2</sup> cable. This needs to be connected to the red M8 terminal on the rear contactor (solenoid) and preferably via a large 500amp (continuous) cut off switch (see picture above).

The heavy earth connection needs to be a minimum 50mm<sup>2</sup> cable and connected to the bottom of the motors using the M8 fixings supplied. This should be returned to the battery for best results.

You then need to connect the red and green solenoid switch wiring. We recommend that you fit momentary on/off/momentary on style toggle switches inside the cab within easy reach of the driver and ideally mounted next to your FreeSpool switch. The switching feed required is 24v if using 24v solenoids and should be fused.

We suggest using no less than a 50amp 24v alternator and recommend using Odyssey PC1500 or PC1700 batteries, although other gel and AGM type batteries designed for high discharge are also suitable.

**Caution - Electrical systems are only as good as their connections. Use high quality cables and battery terminals. Giggiepin can supply a large range of components and premade cables for any winch install.**

### Over-Volting

Over-volting is the when 24v is used to power 12v motors. Over-volted systems are favoured by race teams as they provide more power and speed, providing maximum motor torque in the mid-range.

**We only recommend this set up for experienced users.**

Using an over-volted system you have the choice of using either 12v or 24v solenoids.

The only difference between the solenoids is the voltage used to switch them. Please be sure you have the correct solenoids for your set up.

To Over-volt your winch you will require a heavy 24v feed using a minimum of a 60mm<sup>2</sup> cable. This needs to be connected to red M8 terminal on the rear contactor and preferably via a large 500amp (continuous) cut off switch such as the type pictured on the previous page and needs to be mounted somewhere it can be easily accessed.

The heavy earth connection needs to be a minimum of a 60mm<sup>2</sup> cable and connected to the bottom of the motors using the M8 fixings supplied. This must return to the battery for best results.

You then need to connect the red and green solenoid switch wiring. We recommend that you fit momentary on/off/momentary on style toggle switches inside the cab within easy reach of the driver and ideally mounted next to your FreeSpool switch. The switching feed required is 24v if using 24v solenoids and 12v if using 12v solenoids and should be fused.

We suggest using no less than a 80 amp 24v alternator and recommend using Odyssey PC1500 or PC1700 batteries, although other gel and AGM type batteries designed for high discharge are also suitable.

**Warning - Over volting is not for inexperienced users. Extreme caution must be taken when over volting. Never stall your winch and always make sure your kill switch is easily accessible.**

**Caution - Electrical systems are only as good as their connections. Use high quality cables and battery terminals. Giggiepin can supply a large range of components and premade cables for any winch install.**



## e. Brakes (including MBS)

**GP50 winches** come fitted with an external mechanical cam operated disc brake as standard. This type of brake is a load brake. A “Load brake” stops the winch from paying out rope when a load is applied e.g. if the vehicle is on a hill the load brake will not allow rope to pay out stopping the vehicle from rolling backward.

However the brake is clever enough to allow the user to pay out rope by engaging the motor if required.

The load brake has a pair of large, heavy duty brake pads and is external to the winch. This makes it ideal for use with the synthetic ropes that Gigglepín recommend.

The load brake will not stop winch motor over run and you should practice with your winch to understand how much motor over run you have. This can be varied due to different winch specifications.

**Note - For Brake Maintenance please see Section 4.**

### **Motor Brake System (MBS)**

This is a must have system for those who want total control.

The MBS is an “Over Run” brake. “Over Run” is when the motor continues to turn after the winch switch is released.

The Gigglepín MBS stops the motor instantly when the switch is released. It works autonomous and can be switched on or off as the user requires allowing the user to choose between the option of having over run and no over run.

The MBS can be engaged or disengaged at any time giving the user full flexibility.

If air supply is lost, the MBS will default to ‘Off’, meaning the winch can continue to be used with the load brake.

The MBS does not affect the standard brake fitted to the GP50

The Gigglepín MBS can be fitted on to new and second-hand winches allowing the user to upgrade their winch at any time.

On Winches fitted with MBS there is a third brown wire on the solenoid harness. This wire must be run to a switch fitted near to the other winch control switches. We strongly recommend that a fighter pilot style safety switch cover is used to stop accidental operation. The switch will require a fused 12v or 24v supply dependant on the system ordered by the customer.

**Note - Please see Section 7, Page 21 for wiring diagram.**



## 3. Rigging and Winching Advice and Tips

GP50 winches are designed for multiple recovery situations and can be used static or attached to a vehicle or moving platform.

It is impossible to cover every situation in this handbook, but we will cover some basic recovery techniques.

### Recovering your Vehicle

Your vehicle has become impeded and you are no longer able to drive or the way ahead clearly requires a winch recovery. You must stop and be sure your vehicle is safe and secure.

Then a suitable winch recovery point must be found.

The anchor point needs to be beyond the area where traction has been or is likely to be lost.

The recovery point must be a static point. The most likely will be another vehicle, a tree, rock or possibly a ground anchor.

Check that the recovery point is secure and will not break or move when a winching load is applied.

A winch always pulls in straight lines so be sure that you are recovering your vehicle in the correct direction.

When setting up your winch line always use recovery strops to protect trees and rock protectors to save the winch rope from damage. If you are recovering to another vehicle, be sure that the recovery point is securely mounted.

If possible, always anchor the winch line high up, so the winch helps to raise the vehicle during the recovery.

Gigglepin GP50 winches are designed for assistive winch recovery and it is recommended that the vehicle being recovered drives its wheels during the recovery process.

For best results use a low gear and match the wheel speed of the vehicle to the speed of the winch.

This will give maximum traction during the recovery process.

**Note - The winch is at its most powerful when it has the least amount of rope on the drum**

**Caution - Spinning the wheels of the vehicle being recovered causes lack of control, danger for others and possible vehicle damage.**

**Warning - If the winch stalls during the recovery process you must STOP! Look for obstructions and change your rigging accordingly. In very extreme situations a snatch block might be required.**

### Recovering another vehicle

Before you start the recovery process you need to assess the vehicle that requires recovery.

Is it safe? and are its recovery points suitable? If so, then you may continue.

Always place your vehicle in an area that allows you to recover the stranded vehicle to beyond the area where traction has been lost. If possible always anchor the recovery vehicle to a suitable point such as a tree, rock or another vehicle. Use radios, telephones or assistants to determine when the recovery will start and when it has finished. When winching, keep the load constant but be ready to stop if the load becomes too great or danger is incurred. The vehicle being recovered should assist the recovery (if possible) by turning its wheels at the same speed as the winch.

### After a recovery has taken place

When you have finished making your recovery, remove the rope from the drum and check for damage. Then re-spool the rope on to the drum.

Give the winch a visual check to make sure everything is ok.

Clean and store your recovery kit taking care to check for any damage that might have taken place.

Replace or repair any damaged components as required

**Note - Remember not all winching situations are the same. Take your time to set up the recovery and always inspect and clean your kit before putting it away.**

## a. Common Winch Hand Signals

While winching, you may choose to have someone else to help you. One person directs the operation and watches the winch outside of the vehicle while the other is in control of the winch and vehicle. In these cases it is important that both people agree in and understand the basic winch hand signals.

**Winch In** – Upper arm straight out, lower arm pointing up, index fingers moving in circles.

**Winch Out** – Upper arm straight out, lower arm pointing down, index fingers moving in circles.

**Stop** – Arm raised, hand in fist, motionless.

**Bump In** – Upper arm straight out, lower arm pointing up move thumb and fingers in clam-shell motion repeatedly, for operator to run the winch in, using quick intervals.

**Hands in Winch** – Both arms held out, fingers extended, in the direction of the winch. Operator to stop the winch so the winch can be FreeSpooled or winch hook can be secured.



## b. Winch Remotes and Radios

In recent times new technologies have advanced winch operation and we now have access to excellent radios and wireless winch controls.

**Wireless winch controls** are great tools but care must be taken at all times to prevent the threat of accidents. Always be aware of who is using the remote and always make sure that all assistants or co drivers are clear of the winch and cable before the remote is used. After use, make sure the remote is switched off before being stowed. If the remote is not to be used for a long period of time, it is best to remove the battery(s) to stop possible corrosion.

**Radios** are a great tool to use when winching and allow the winch operator and their assistants to communicate. Before you start winching always decide on key words or phrases to be used during the winching procedure. This will stop confusion during the winching process. Keep it simple and short.

Our suggested phrases are -

Winch in

Winch out

Lock FreeSpool

Unlock FreeSpool

Stop

**Note - Never say "No" as it sounds too much like "GO" and can cause confusion.**

## 4. Winch Maintenance

### a. Maintaining Your Winch

All winches require maintenance to operate correctly. However every user is different and the wear rates experienced on the Winches varies dependant upon where they are used, and what they are used for. This is a basic guide to general winch maintenance for your GP50 and should be tailored to your application as required. If in doubt please contact your Local Gigglepín Winches supplier with your requirements.

#### **Daily Inspections (after use)**

Check winch mountings and make sure they are tight.  
Check motor connections.  
Check all electrical connections for tension and corrosion.  
Check the brake pawl moves freely and is unhindered.  
Check the brake pawl spring for operation.  
Test FreeSpool operation and listen for rumbling bearings.  
Test the winch works in both directions.

**Note - to test each motor, remove the central earth wire from one of the solenoids and test the winch in both directions. Then refit and remove the other solenoid central terminal. This will determine if the motors and solenoids are working correctly.**

#### **Monthly Actions**

Grease brake pawl.  
Strip motors, clean thoroughly and inspect brushes and brush springs.  
Remove electric terminals clean, and refit.  
Check the drum free end bearing for wear or corrosion.  
Check FairLead for wear.

#### **Yearly Actions**

Strip, clean and rebuild the load brake using new parts as required.  
Strip, clean and rebuild the MBS brake (if fitted) using new parts as required.  
Drain and refill gearbox using 0.50Litres of 30W gear oil or GP HD Winch Oil (G10014).

#### **2 Yearly Actions**

Strip complete winch and check over all component parts.  
Replace all seals and bearings as required.

**Note - All service parts are available from Gigglepín Winches.**

**Note - Full parts diagrams can be found in Section 7.**

**Caution - Failure to maintain your winch could lead to voiding your warranty.**

**Warning - Failure to maintain your winch could lead to premature failure.**

## b. Maintaining Your Rope

**Remember gloves should always be worn when handling any winch rope.**

Inspect the rope by FreeSpooling the rope off the winch drum. Look for any cuts, fraying, broken strands or any other physical damage. Clean your winch rope by removing dirt or debris. It is your responsibility to maintain your winch rope with proper maintenance to prolong the life of your winch rope.

After inspecting your rope, clean and re-spool it neatly onto your winch. This should be done evenly with some tension on the rope, to ensure a uniform and tight wrap onto the winch drum.

When synthetic rope is new it has a smooth finish. When the rope is used for the first time the outer filaments of the rope will roughen and give the rope a slightly fuzzy/frayed appearance. Don't panic - this condition of the outer filaments creates a rougher rope surface and actually helps to protect the fibres underneath.

Examine both inner and outer fibres. To do this open the strands of the rope by compressing the rope length-wise and look for powdered fibre and abrasion (this is a sign of internal wear of the winch rope). Estimate internal fibre loss to include in the overall abrasion fibre loss of the rope.

**Minimise the rope abrasion** – Use a rope protector or rock guards whenever the rope comes into contact with rocks or other objects.

**Keep the rope clean** - Allowing dirt and debris to enter the rope will lead to abrasion of the rope.

**Avoid sharp bends** – A sharp bend in the rope decreases its strength substantially under load and may cause rope damage or failure.

## c. Top Tips for Your GP50

- Inspect your winch regularly before and after every use.
- Do not use damaged equipment or a winch that isn't operating properly.
- Listen to your winch. Learn to recognise when the winch is pulling easily, and when its working harder.
- Avoid long-duration pulls at high loads. Allow the winch to rest.
- Always keep safety as a top priority, and be considerate of others and the environment.
- Do **NOT** leave the load brake assembly locked. Always make sure the ratchet can turn freely if the winch is being stored between uses.

**If you need service kits or any spares don't hesitate to get into contact with your local Giggiepin Supplier or contact us directly.  
Shop@Giggiepin4x4.net or +44(0) 1732 463 600**





## 5. Warranty

Gigglepin GP50 winches come with a three year mechanical breakdown warranty. This covers any manufacturing fault or defect with the gears, casings or drum.

It **does NOT** cover -

- Motor or solenoid
- Drum end bearings suffering water or dirt ingress.
- Brakes worn or damaged through over usage, lack of maintenance, water or dirt ingress.
- Damage resulting from the winch being hit or struck by external forces.
- Damage resulting from a weak, bent or unsuitable winch mount.
- Damage from snatch loading to the gearbox.
- Damage resulting from running with no oil.

**Please feel free to contact your local Gigglepin Supplier or contact us directly if you have a problem as we will always try to help in any way we can.**

## 6. Contact Information

**If you have any problems or any queries please contact your local Gigglepin Supplier or contact us directly.**

Gigglepin 4x4  
Unit 10,  
Gaza Trading Estate,  
Scabharbour Road,  
Hildenborough,  
Kent TN11 8PL

[www.GigglepinWinches.com](http://www.GigglepinWinches.com)

[Shop@Gigglepin4x4.net](mailto:Shop@Gigglepin4x4.net)

+44 (0) 1732 463600



## 7. Technical Data

### a. TopHousing Diagram

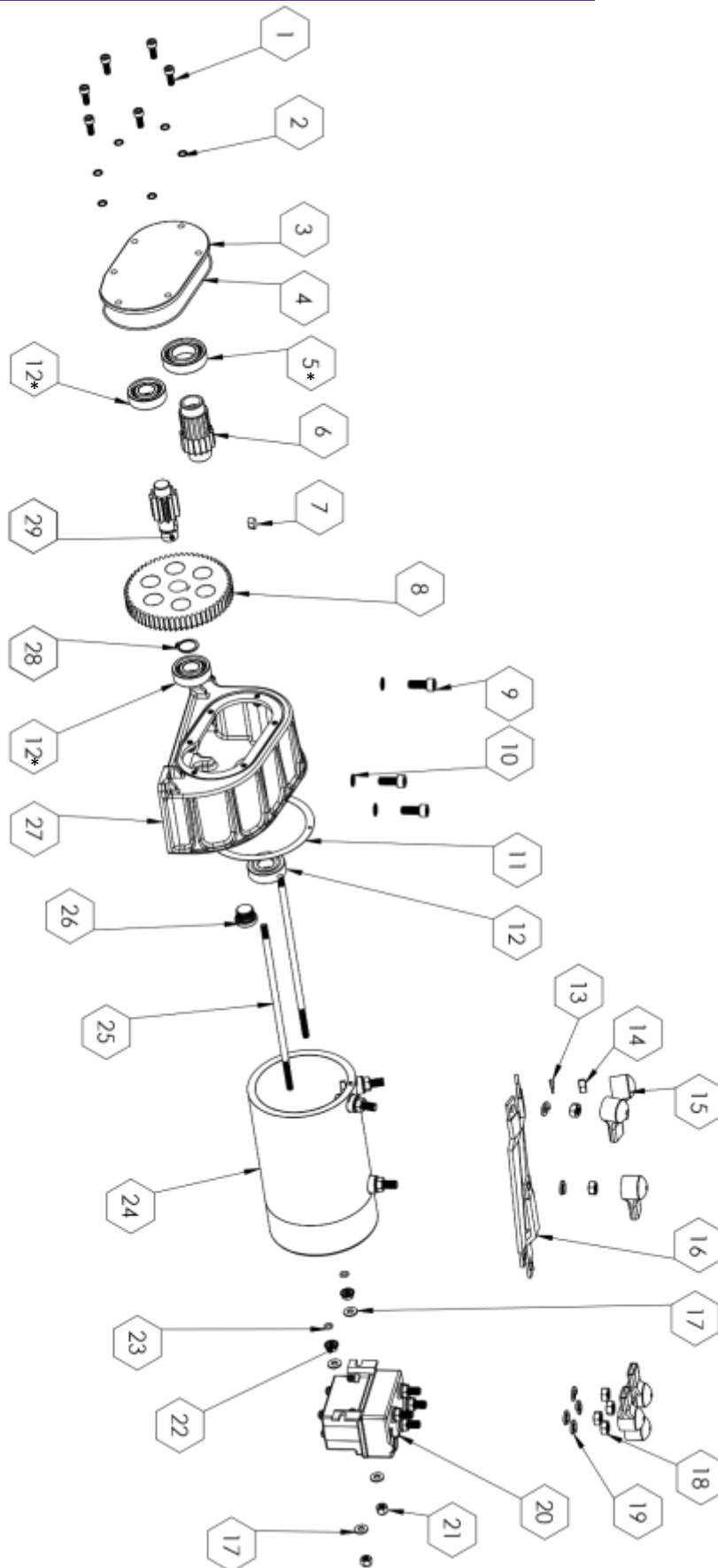

\* Please note that these bearings have the seals removed.

## a. TopHousing Diagram (Cont'd)

Item	Quantity	Product No.	Description	Notes
1	6	GP47	M6 Schnorr Washer	Part of TopHousing Service Kit - G17020
2	6	GP46	M6 x 16 Cap Head Bolt	Part of TopHousing Service Kit - G17020
3	1		SingleMotor Cover Plate	
4	1		SingleMotor "O" Ring	
5	1	GP49	6005 Bearing	Part of TopHousing Service Kit - G17020
6	1	See Notes	SingleMotor TopHousing Pinion Gear	
7	1	BRK6	1/4 x 1/4 Woodruff Key	Part of TopHousing Gear Set - G18STH00/15/25/40/50/60
8	1	See Notes	SingleMotor Centre Gear	Part of TopHousing Gear Set - G18STH00/15/25/40/50/60
9	3	GP44	M8 x 20 Cap Head Set Screw	
10	3	GP45	M8 Schnorr Washer	
11	1	G11004	Motor Gasket	
12	2		6203 Bearing	Part of TopHousing Service Kit - G17020
13	3	See Notes	M8 Split Washer Steel	Available with Bow Motors
14	3	See Notes	M8 Nut Steel	Available with Bow Motors
15	6	G16010	PowerBar Boots	Part of PowerBar Kits - G16012/G16011
16		See Notes	SingleMotor PowerBar Kit	Available in Different Sizes - G16012/G17019
17	4	GP6	M6 Flat Washer	Available with Extended MotorBolts - G10001/G17016
18	4	See Notes	M8 Nut Stainless Steel	Available with Solenoid - G19003/G19004
19	4	See Notes	M8 Split Washer Stainless Steel	Available with Solenoid - G19003/G19004
20	1	See Notes	Pro Series Solenoid	Available in - 12v G19003 or 24v G19004
21	2	MB4	M6 Nyloc Nut	Available with Extended MotorBolts - G10001/G17016
22	4	GP6	M6 Flat Washer	
23	2	See Notes	Extended MotorBolt O-Ring	Available with Extended MotorBolts - G10001/G17016
24	1	See Notes	Bow Motor 2 or 2 Plus	Available in 12v or 24v
25	2	See Notes	Extended MotorBolts	Available with Extended MotorBolts - G10001/G17016
26	1	G42	Oil Plug	
27	1		TopHousing Casing	
28	1	See Notes	Circlip	Available with Ratio Gear Kit
29	1	See Notes	SingleMotor TopHousing Centre Gear Shaft	Part of TopHousing Gear Set - G18STH00/15/25/40/50/60

## b. LowerHousing Diagram

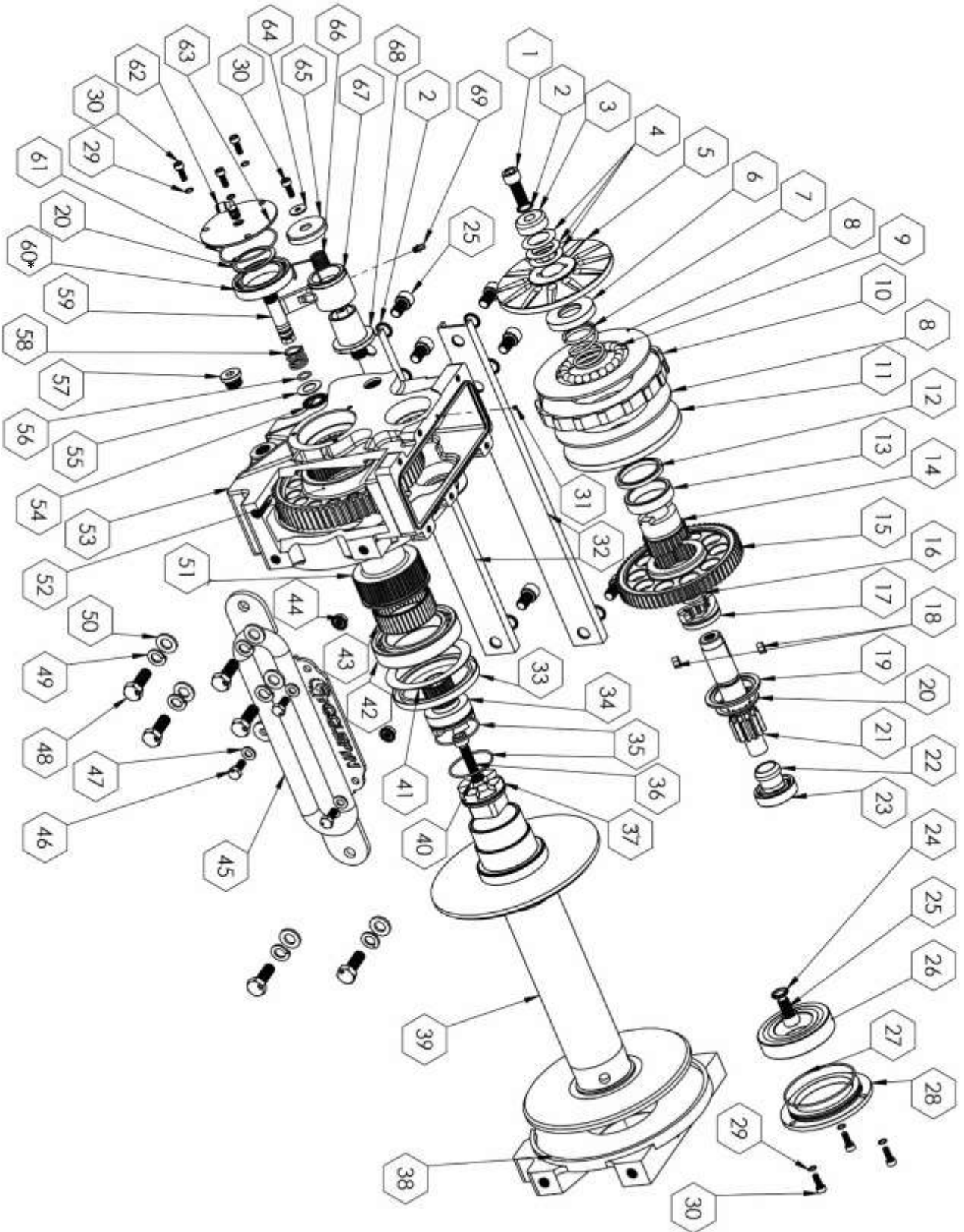

\* Please note that these bearings have the seals removed.

## b. LowerHousing Diagram (Cont'd)

Item	Quantity	Product No.	Description	Notes
1	1	See Notes	SuperShaft Bolt	Part of SuperShaft Kit - G60101/G60102
2	7	See Notes	M12 Schnorr Washer	Part of SuperShaft Kit - G60101/G60102
3	1	See Notes	SuperShaft End Cap	Part of SuperShaft Kit - G60101/G60102
4	3	See Notes	Belleville Washer	Supplied in Brake Kits - G13010/G90002
5	1	See Notes	Billet Brake Disc - Outer	Part of Billet Brake Assembly - G7634
6	1	See Notes	Brake Spacer	Supplied in Brake Kits - G13010/G90002
7	1	See Notes	Brake Spring	Supplied in Brake Kits - G13010/G90002
8	2	G60201	Heavy Duty Brake Disc Shoe	Also part of Brake Rebuild Kit G13010
9	21	See Notes	Stainless Steel Ball Bearings	Supplied in Brake Kits - G13010/G90002
10	1	See Notes	Billet Brake Ratchet Disc	Part of Billet Brake Assembly - G7634
11	1	See Notes	Billet Brake Disc - Inner	Part of Billet Brake Assembly - G7634
12	1	SSK1	Oil Seal	Also part of Seal Kit - G60401
13	1	G7611	Bronze Bush	
14	1	G60121	Large Cam Gear	Also part of SuperShaft Kit - G60102
15	1	G7548	Intermediate Gear 7548	
16	1	See Notes	MainShaft O-Ring	Part of SuperShaft Kit - G60101/G60102 & Seal Kit - G60401
17	1	G60122	Small Cam Gear	Also Part of SuperShaft Kit - G60101/G60102
18	2	See Notes	1/4 x 1/4 Woodruff Key	Supplied in Brake Kits - G13010/G90002
19	1	See Notes	Stepped Spacer	Supplied in Brake Kits - G13010/G90002
20	2	See Notes	MainShaft & 7550 Circlip	Part of Kits - G60101/G60102/G19002/G19008
21	1	See Notes	SuperShaft	Part of SuperShaft Kit - G60101/G60102
22	1	GP38	Bearing Adapter	
23	1	GP49	6005 Bearing	Also Known as Main Shaft Bearing – GP49
24	1	GP24	M12 Dowty Washer	
25	7	GP23	M12 x 20 Cap Head Bolt	
26	1	GP79	Drum End Bearing	
27	1	GP21	Drum End O-Ring	
28	1	GP20	Drum Support Plate Cover	
29	6	GP47	M6 Schnorr Washer	
30	7	See Notes	M6 x 16 Cap Head Bolt	Supplied in Brake Pawl Kit - G7605
31	1	GP37	M4 Grub Screw	
32	2	G17014/15	BraceBar	Available in 3 Different Sizes - Short, Standard and Long
33	1	GP28	Drum Seal	
34	1	GP2	Drive Piston	
35	2	GP18	FreeSpool Piston O-Ring	
36	1	GP16	M10 x 45 Cap Head Bolt	
37	1	GP3	Drive Dog	
38	1	GP19	Billet Drum Support Plate	
39	1	NSS	Winch Drum	Available in 3 Different Sizes - Short, Standard and Long
40	1	GP17	M10 Dowty Washer	
41	1	GP27	Oil Thrower	
42	1	GP26	Drum Bearing	
43	1	GP7	Cage Bearing	
44	3	See Notes	M8 Flange Nut	Available with FairLead
45	1	G17005/6/7	GP Stainless FairLead	Available in 3 Different Sizes - Short, Standard and Long
46	3	See Notes	M8 x 20 Set Screw	Available with FairLead
47	3	See Notes	M8 Flat Washer	Available with FairLead
48	6	GP29	M12 x 35 Set Screw	
49	6	GP30	M12 Split Washer	
50	6	GP31	M12 Flat Washer	
51	1	GP1	7550 Carrier	
52	1	G7550	Main Gear 7550	
53	1	GP39	GP50 Lower housing	
54	1	GP13	Thrust Bearing	
55	1	GP12	Thrust Washer	
56	1	GP15	Piston Rod O-Ring	
57	1	GP42	Oil Plug	
58	1	GP14	Piston Spring	
59	1	GP11	Piston Rod	
60	1	GP8	Carrier Bearing	
61	1	GP10	Cover Plate O-Ring	
62	1	90186	90° Breather Elbow 1/8BSP / 6mm	
63	1	GP9	LowerHousing CoverPlate	
64	1	GP6	M6 Flat Washer	Part of Brake Pawl Kit - G7605
65	1	GP36	Brake Pawl Cover	Part of Brake Pawl Kit - G7605
66	1	G9257	Brake Pawl Spring	Also Available in Brake Pawl Kit - G7605
67	1	GP35	Brake Pawl	Part of Brake Pawl Kit - G7605
68	1	GP34	Brake Pawl Mount	
69	1	GP51	M6 Grease Nipple	Part of Brake Pawl Kit - G7605
	1	G10014	Heavy Duty Winch Oil 250ml	250ml One Shot Winch Oil

### c. Winch Wiring Diagram - 12V

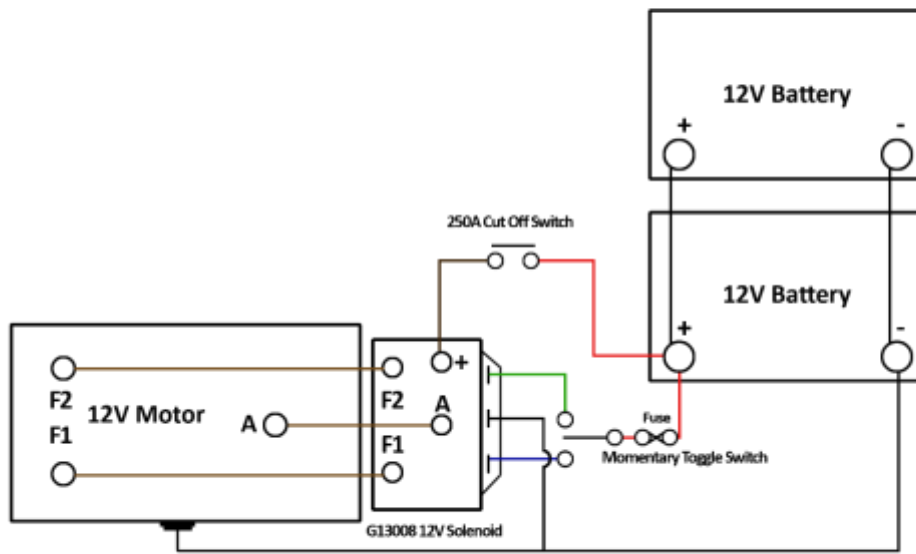

### d. Winch Wiring Diagram - 24V

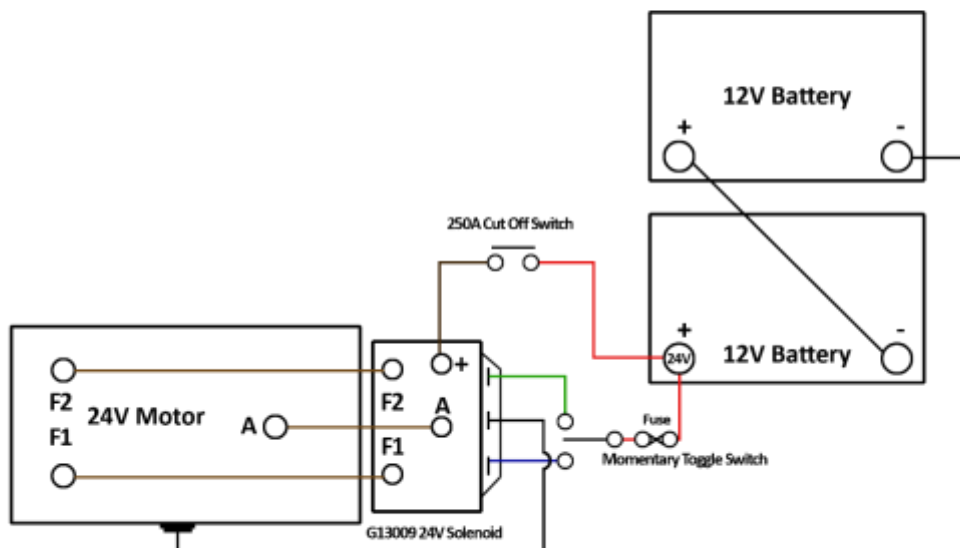

## e. Winch Wiring Diagram - OverVolting

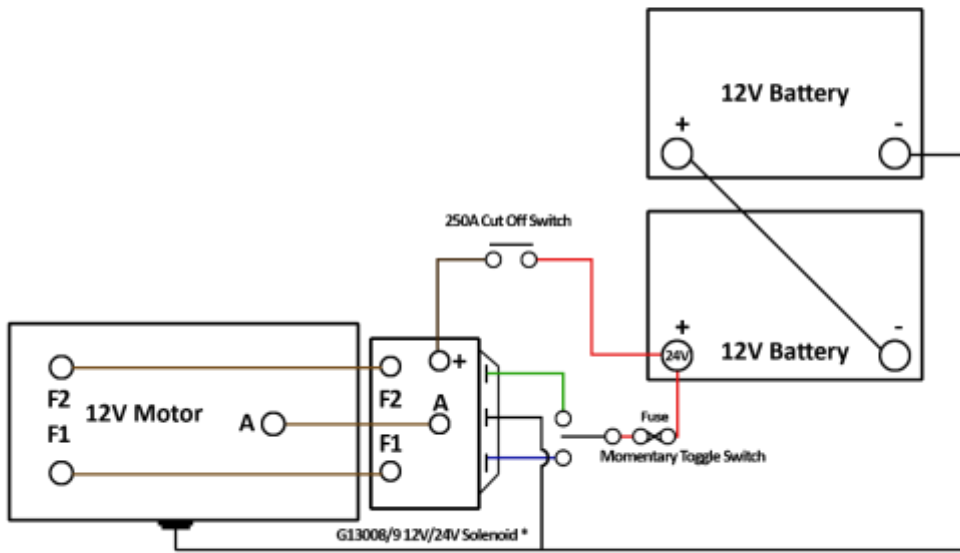

\* Use 24V Solenoid if switch current is 24V. If Switching current is 12V, use 12V Solenoids

## f. FreeSpool Air Solenoid Wiring Diagram

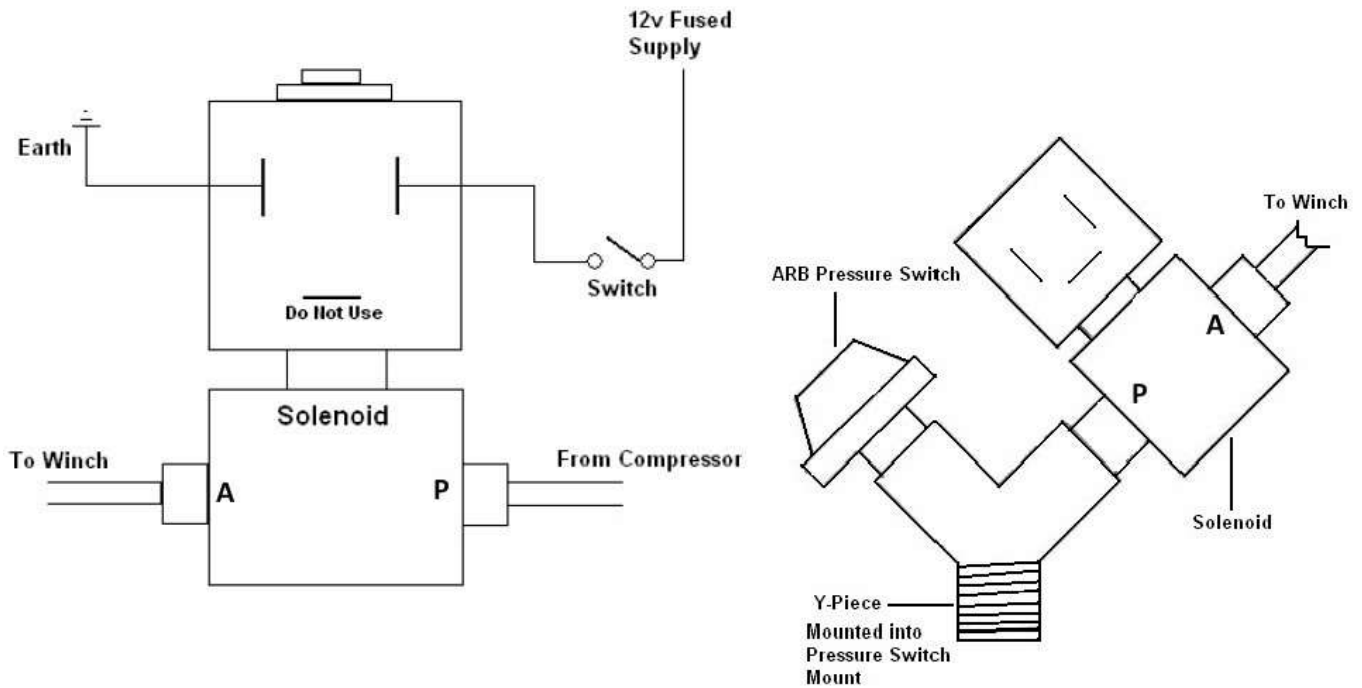

## g. Winch Wiring Diagram 12V Fitted with MBS

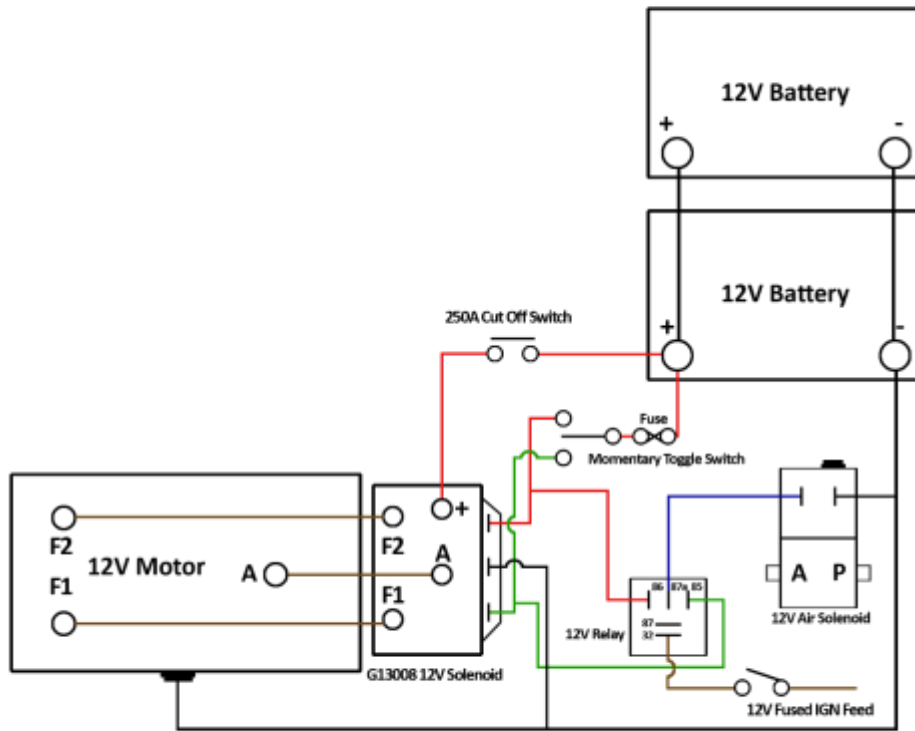

## h. Winch Wiring Diagram 24V Fitted with MBS

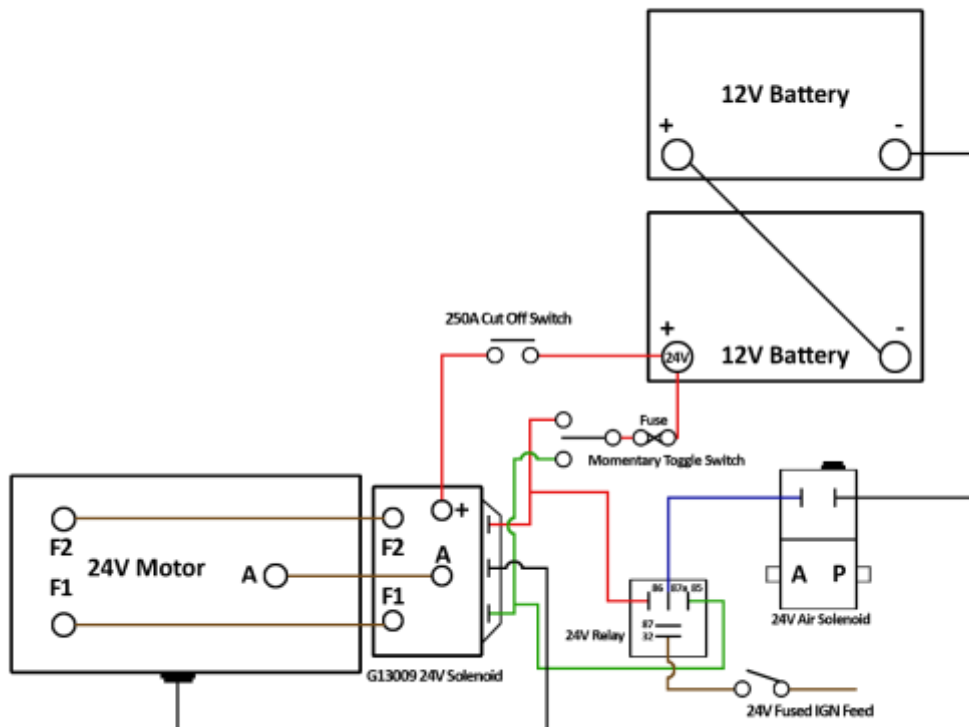



# i. Winch Dimensions – Short Drum

Please note the measurements are in Millimetres.

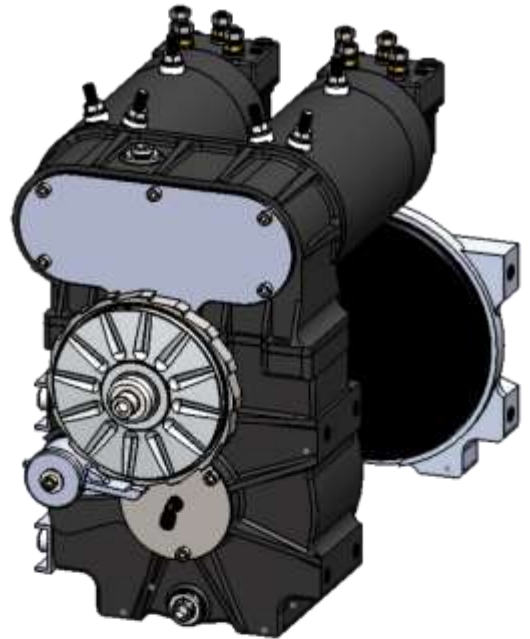

Width and Height

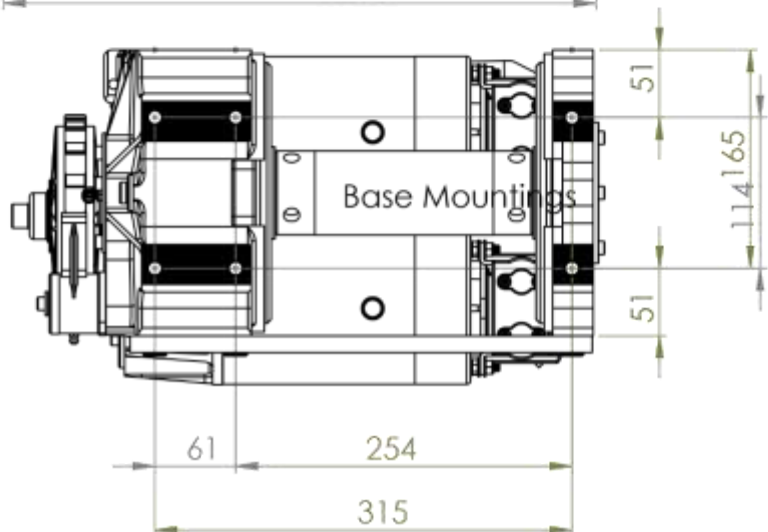
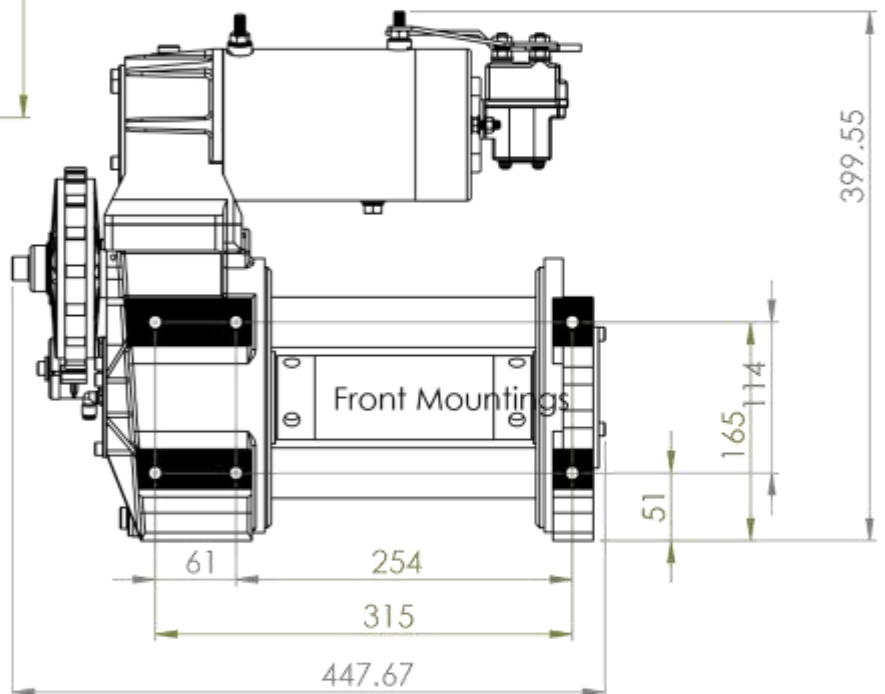
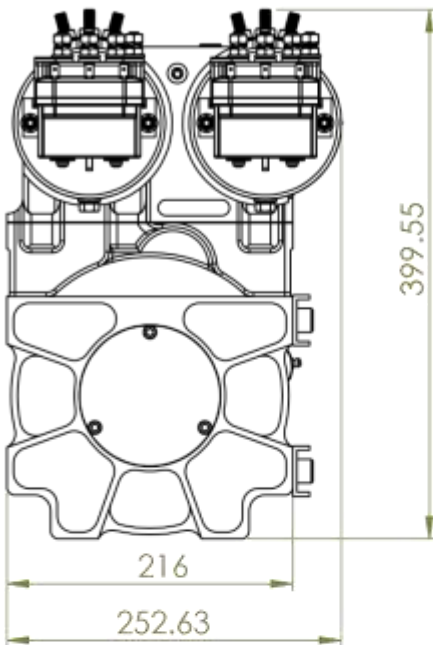

## j. Winch Dimensions – Standard Drum

Please note the measurements are in Millimetres.

Width and Height

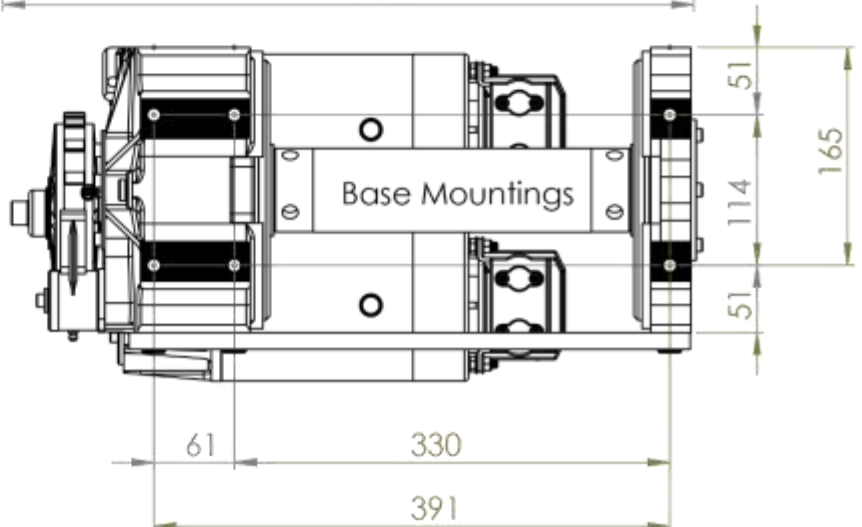
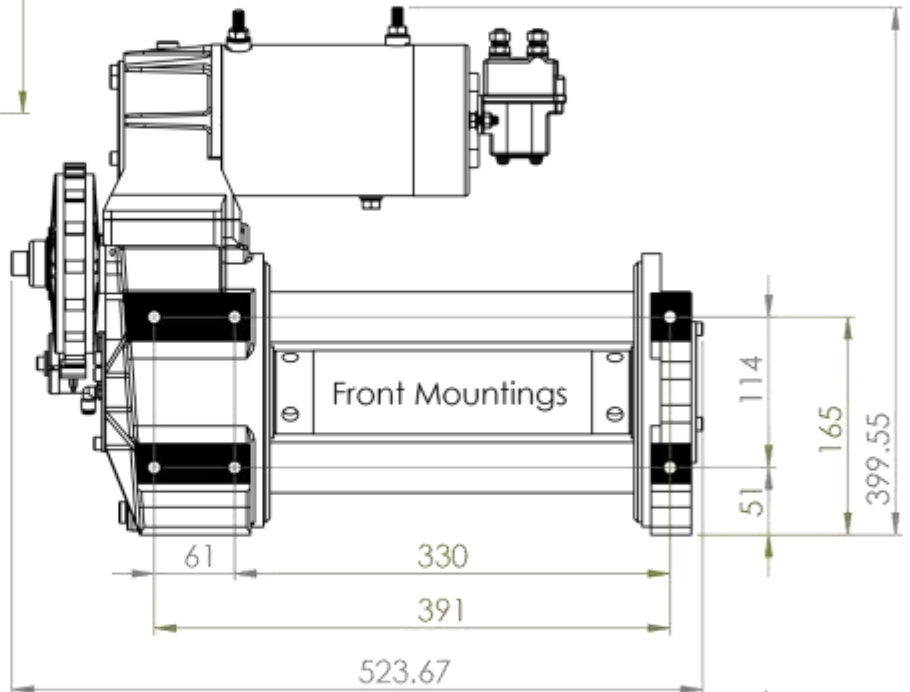
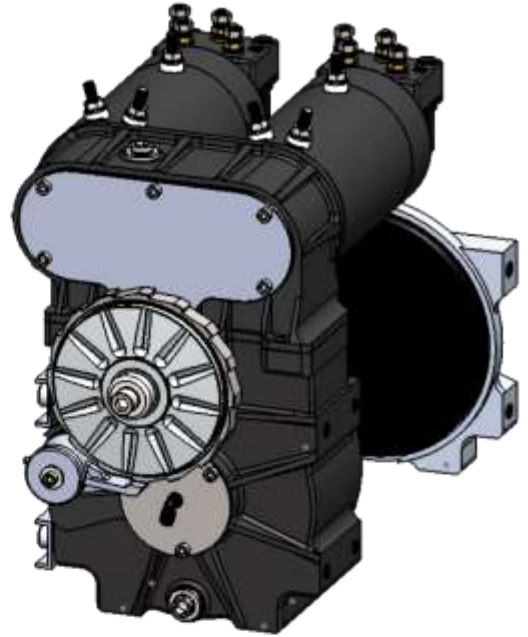
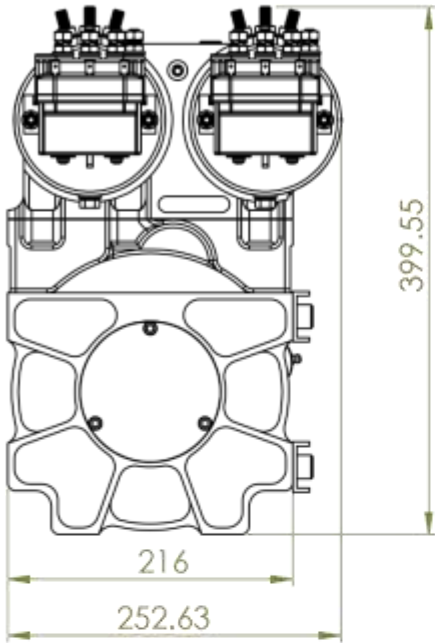

## k. Winch Dimensions – Long Drum

Please note the measurements are in Millimetres.

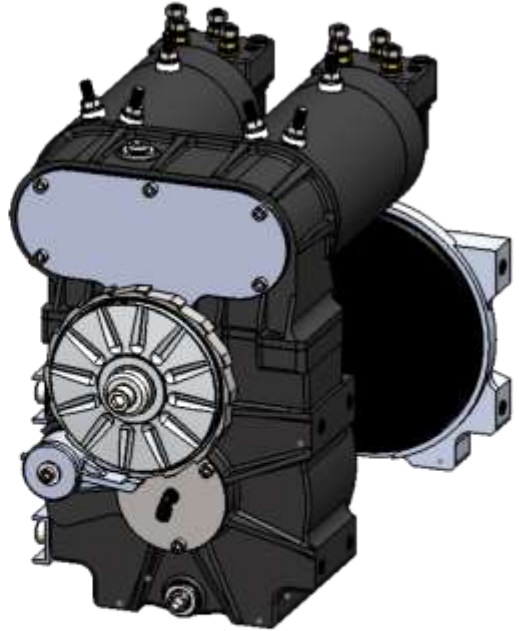

Width and Height

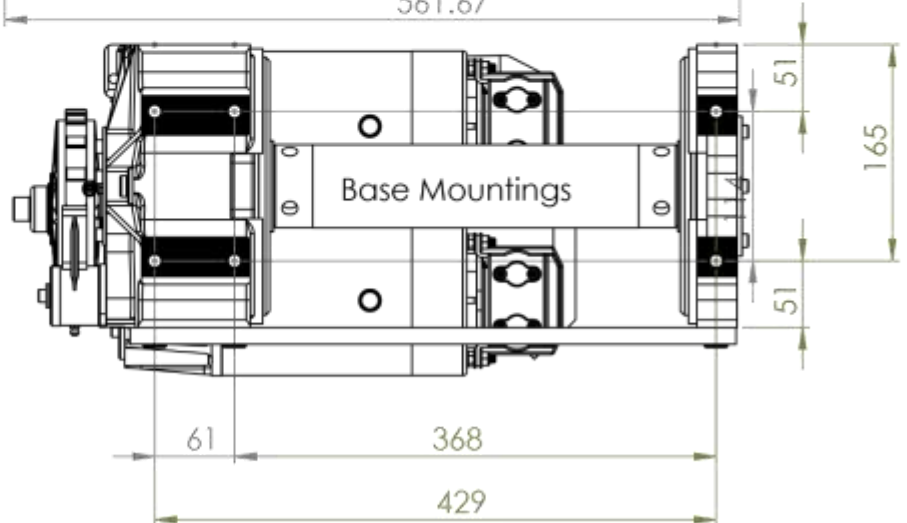
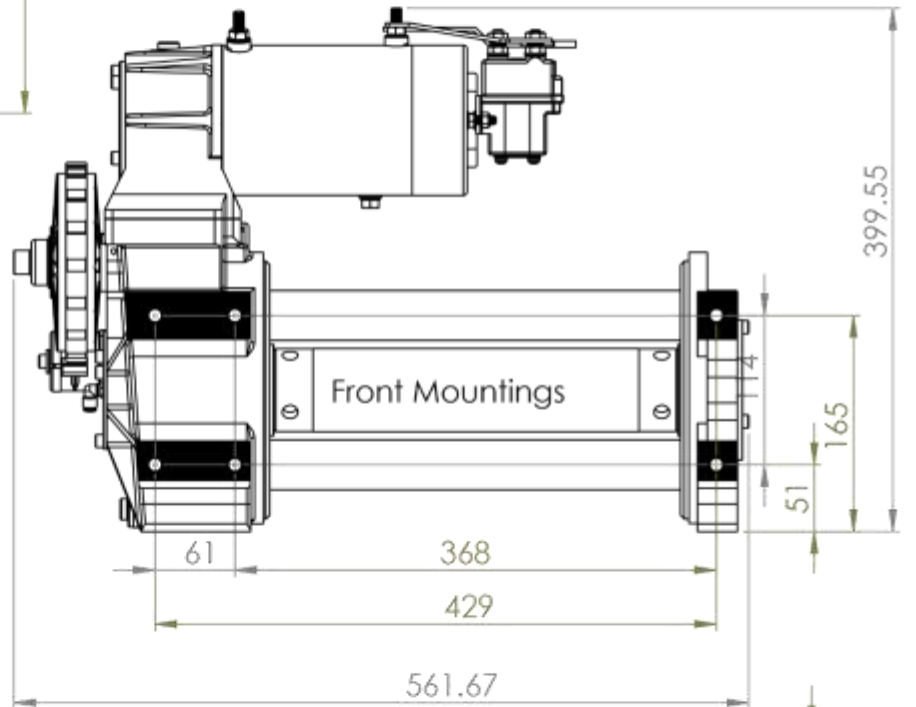
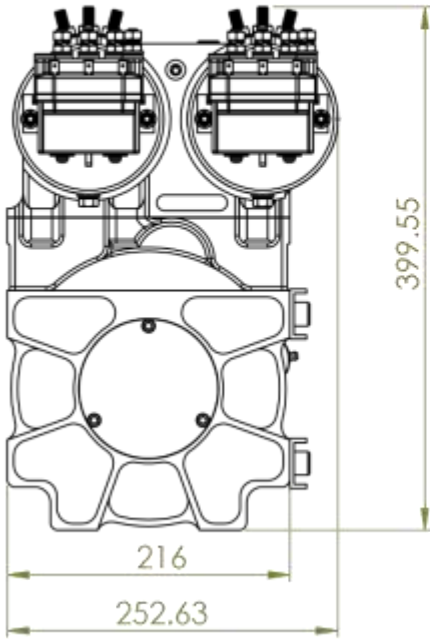

## I. GP50 FairLead Mounting for Underwound

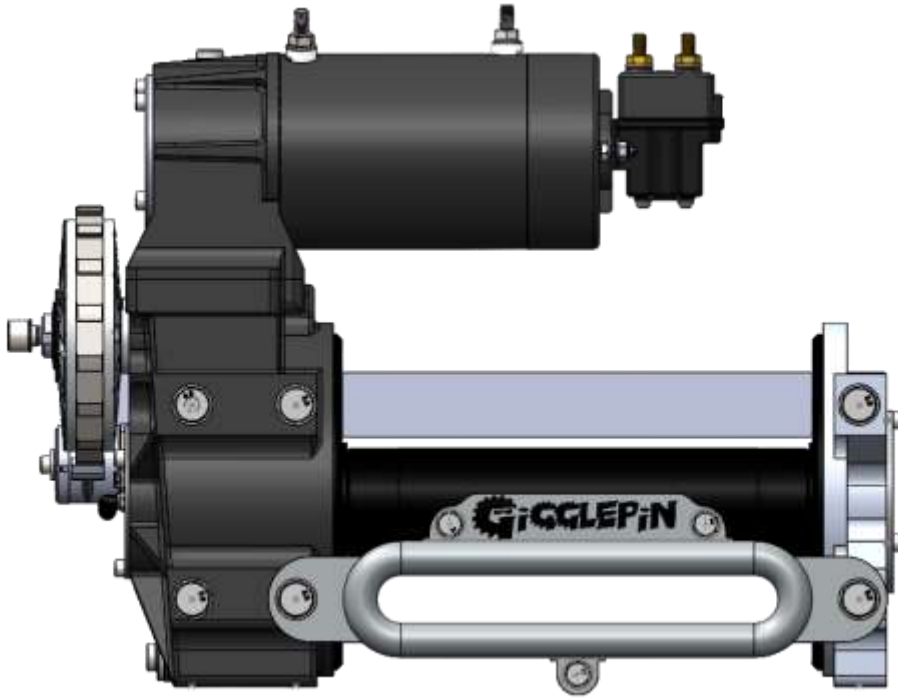

Note – These diagrams are for demonstration purposes only as there should be a Winch Mount/Tray present to which the FairLead would be mounted to.

## m. GP50 FairLead Mounting for Overwound

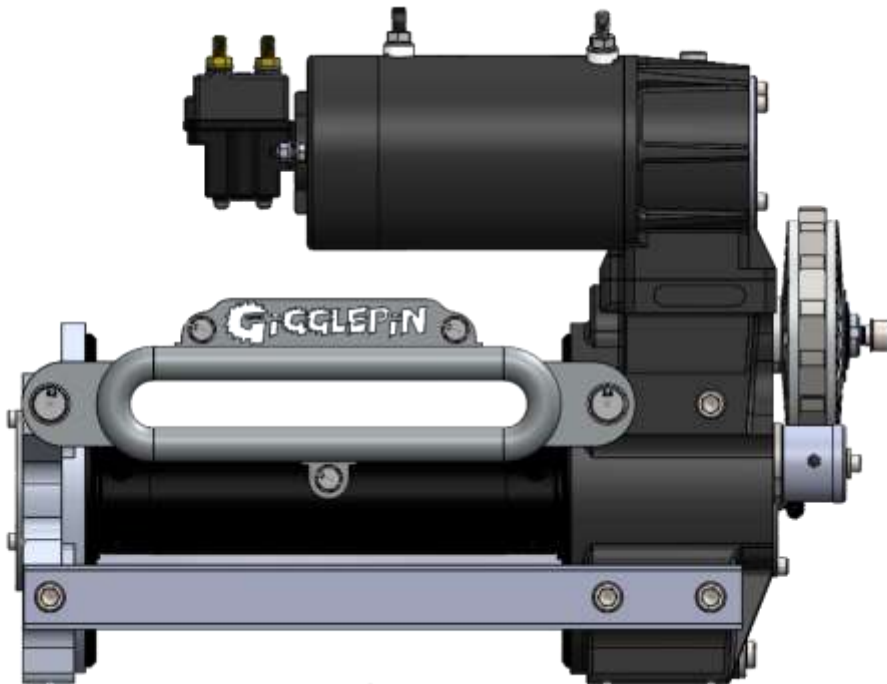

Note – Always use the supplied 20mm bolts when fixing to the rear of the casing.

Note – These diagrams are for demonstration purposes only as there should be a Winch Mount/Tray present to which the FairLead would be mounted to.



**Note – You can mount the winch various different angles, but we recommend this must not be less than 20 degrees from horizontal, so as not to affect gearbox operation and to prevent oil pooling in the TopHousing.**



## 6. Glossary

**Drum** – Tube with flanges to store rope.

**Drum Support Plate** – Part of the winch which is typically used to mount a winch or hold a winch drum.

**Disengaged** – The winch clutch position in which FreeSpooling can take place.

**Engaged** – The winch clutch position in which winch operation can take place.

**FairLead** – A device, often with vertical and horizontal rollers, mounted in front of the winch that aids guiding the rope onto the winch drum, and taking side loads.

**FreeSpool** – When the winch has been placed into a disengaged position that allows the rope to be pulled off the drum by hand.

**Jog (Jog in)** – Operating the winch in quick pulses of 1 second while snugging up the hook after using the winch. (Do not jog under load).

**Underwound** – Where the winch rope under tension comes off the drum from under the rope wound onto the drum (the bottom of the drum. Most winches are set up this way).

**Overwound** – Where the winch rope comes off the drum over the rope wound onto the drum (the opposite of under wound).

**Snatch Block** – A winching accessory which has a grooved pulley to allow multiple lines to be attached to the load or for changing the direction of the pull.

**Rigging** – Materials used to rig your winch. (Treelinx, Snatch blocks, Linx straps).

**RockGuard** – A winching accessory which lays under the rope to stop it getting worn down by rocks.

**Solenoid** – An assembly used as a switch, consisting of a coil and metal core free to slide along the coil axis under the influence of an electrical magnetic field.

**Stall** – Where the winch has pulled its maximum amount, and the drum is no longer turning. (Do not continue to apply power to a stalled winch).

**BraceBar (Tie Bar)** – Part of the winch assembly inserted between drum supports designed to maintain a constant distance between drum supports.

**TreeLinx Strap** – A looped strap placed around a tree, rock or other object to attach the winch hook, protecting the tree from damage.

**Winch** – A device intended for pulling horizontally while keeping contact with the ground.

# 9. GP50 TopHousing Ratios & the Hurricane Gearset

The GP50 is offered with the choice of six different TopHousing ratios so that we can find the perfect match of power and speed, tailored to each individual user and application, and your ratio fitment will be stamped in the top of the TopHousing.

The ratio figure is based upon the top housing ratio of a standard Warn 8274, so a STD Ratio is the same as an 8274, but +60% is 60% taller gearing than an 8274. This means that the TopHousing will be 60% faster, but with the resultant loss of power.

Replacement ratio kits are available, so after use, if you are not happy with the ratio supplied with your winch, please contact us or your local Giggiepin Supplier, and we will be happy to help you.

**Please see below for Ratios & Tooth Counts -**

	Top Housing Centre Gear Tooth Count	Top Housing Pinion Gear Tooth Count	7548 Tooth Count	Top Housing Centre Shaft Tooth Count	7550 Tooth Count	MainShaft Tooth Count	Combined ratio	% increase over STD
STD	62	17	67	11	66	11	133.28 :1	0
+ 15%	60	19	67	11	66	11	115.41 :1	13
+ 25%	58	21	67	11	66	11	100.94 :1	24
+ 40%	55	24	67	11	66	11	83.75 :1	37
+ 50%	51	28	67	11	66	11	66.56 :1	50
+ 60%	47	32	67	11	66	11	53.68 :1	60

The Hurricane Gearset (G19002) consists of a replacement smaller Lower Main Gear and a larger SuperShaft (Replacing G7550 and G60101). This makes the overall gearing taller again, giving yet more flexibility to the speed/power balance, meaning there truly is a GP50 for everybody!

**The Hurricane Gearset alters the existing geartrain ratios as follows -**

Top Housing Ratio	Top Housing Centre Gear Tooth Count	Top Housing Pinion Gear Tooth Count	7548 Tooth Count	Top Housing Centre Shaft Tooth Count	7550 Tooth Count	MainShaft Tooth Count	Combined ratio	% increase over STD
STD	62	17	67	11	62	15	91.82 :1	31
+ 15%	60	19	67	11	62	15	79.50 :1	40
+ 25%	58	21	67	11	62	15	69.53 :1	48
+ 40%	55	24	67	11	62	15	57.69 :1	57
+ 50%	51	28	67	11	62	15	45.86 :1	66
+ 60%	47	32	67	11	62	15	36.98 :1	72

Replacement TopHousing Ratio Sets and the Hurricane gear set are available from your local Giggiepin Supplier.



**Left – Ratio Gears.  
Right – Hurricane Gear.**



# GIGGLEPIN WINCH.COM



GigglepinWinches



#GigglepinWinches

**Gigglepin 4x4**

**Unit 10,**

**Gaza Trading Estate,  
Scabharbour Road,**

**Hildenborough,**

**Kent TN11 8PL**

**[www.GigglepinWinches.com](http://www.GigglepinWinches.com)**

**[Shop@Gigglepin4x4.net](http://Shop@Gigglepin4x4.net)**

**+44 (0) 1732 463600**